

# ELECTRICAL PLAN REVIEW

Overcurrent Protection and Devices, Short-Circuit Calculations,  
Component Protection, Selective Coordination, and  
Other Considerations

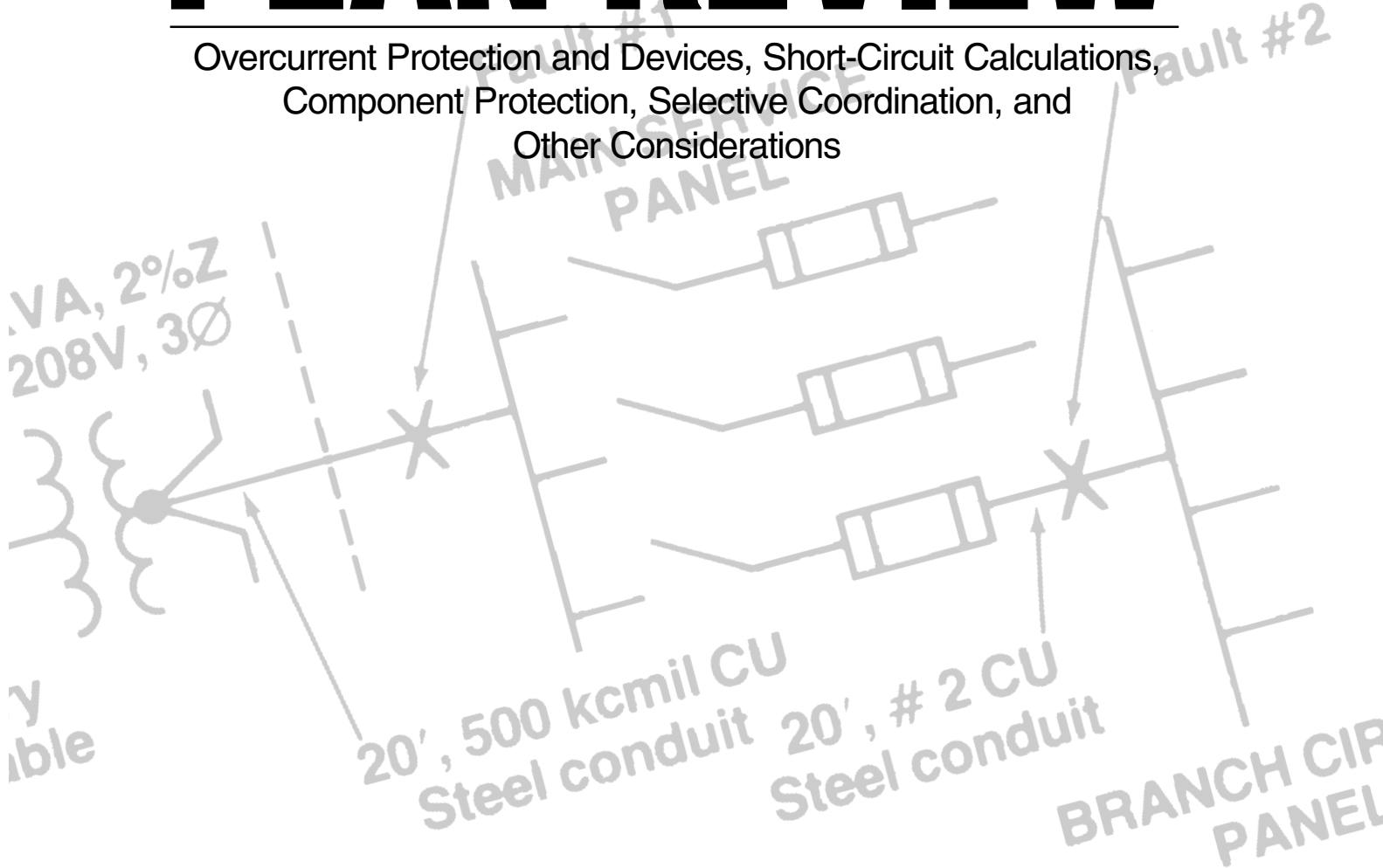

**On-Line Training**

available on [www.bussmann.com](http://www.bussmann.com)

See inside cover for details

**COOPER** Bussmann

# Table of Contents

---

<b>Part I: Overcurrent Protection and Devices</b>	<b>PAGE</b>
Objectives	2
Important NEC® Requirements	3
Overcurrent Protective Device Ratings:	
- Voltage and Ampere Ratings	4
- Interrupting Rating – NEC® 110.9	5
Short-Circuit Currents and Interrupting Rating	6
<hr/>	
<b>Part II: Short-Circuit Calculation</b>	
Point-To-Point Method of Short-Circuit Calculation Formulas and Example	7
Short-Circuit Calculation Charts	8
<hr/>	
<b>Part III: Short-Circuit Calculation Problem and Worksheets</b>	
Problem – Detail Drawing	10
Problem - One-Line Diagram	11
Problem - Worksheet	12
<hr/>	
<b>Part IV: Component Protection</b>	
NEC® 110.10, Current Limitation, and Devices	15
Let-Through Charts	16
Conductor Protection	21
Bus and Busway Protection	22
Motor Circuit Protection	23
Series Ratings	24
<hr/>	
<b>Part V: Selective Coordination</b>	
Selective Coordination	6
Selective Coordination – Circuit Breakers	27
Selective Coordination - Fuses	28
<hr/>	
<b>Part VI: Miscellaneous</b>	
Maintenance and Testing Considerations	29
Grounding and Bonding of Service Equipment	30
Data “Log In” Letter and Form	31
Series Combination Rating Inspection Form	34
Fuse/Circuit Breaker Series Ratings Table	35

# Objectives

---

By reviewing this brochure, the Electrical Inspector, Electrical Contractor, Plan Examiner, Consulting Engineer and others will be able to . . .

- Understand and discuss the critical National Electrical Code® requirements regarding overcurrent protection.
- Understand short-circuit currents and the importance of overcurrent protection.
- Understand the three ratings (voltage, ampere, and interrupting) of overcurrent protective devices.
- Understand that the major sources of short-circuit currents are motors and generators.
- Understand that transformers are NOT a source of short-circuit current.
- Calculate short-circuit currents using the simple POINT-TO-POINT method and related charts.
- Realize that whenever overcurrent protection is discussed, the two most important issues are:
  - HOW MUCH CURRENT WILL FLOW?
  - HOW LONG WILL THE CURRENT FLOW?
- Understand current-limitation and use of let-through charts to determine the let-through current values (peak & RMS) when current-limiting overcurrent devices are used to protect electrical components.
- Apply current-limiting devices to protect downstream electrical components such as conductors, busway, and motor starters.
- Understand series rated combinations and proper application of series rated combinations.
- Understand selective coordination of overcurrent protective devices.
- Understand the meaning and importance of electrical terms commonly used relating to overcurrent protection.
- Understand maintenance, testing, resetting, and replacement requirements of overcurrent protective devices.
- Check electrical plans to determine conformance to the National Electrical Code® including short-circuit currents, interrupting ratings, short-circuit current (withstand) ratings, selective coordination, ground faults, grounding electrode conductors, equipment grounding conductors, etc.
- Verify that circuit, feeder, service, grounding electrode conductors, equipment grounding conductors, and bonding conductors have adequate capacity to conduct safely ANY fault current likely to be imposed on them.
- Adopt a *Form Letter* and a *Data Required Form* that can be used to “log-in” the necessary data relating to available fault currents, interrupting ratings, series combination ratings, selective coordination, short-circuit current (withstand ratings) and let-through currents for protection of electrical components.
- Know how to ask the right questions.

# Important NEC<sup>®</sup> Requirements

---

**Article 100** covers definitions.

**110.3(B)** requires listed or labeled equipment to be installed and used in accordance with any instructions included in the listing or labeling.

**110.9** requires equipment intended to interrupt current at fault levels to have an interrupting rating sufficient for the nominal circuit voltage and the current that is available at the line terminals of the equipment.

**110.10** requires the overcurrent protective devices, the total impedance, the component short-circuit current ratings, and other characteristics of the circuit protected to be selected and coordinated to permit the circuit-protective devices used to clear a fault to do so without extensive damage to the electrical components of the circuit. Listed products applied in accordance with their listing meet this requirement.

**110.16** covers the required flash protection hazard marking of equipment.

**110.22** covers the field labeling requirements when series combination ratings are applied.

**Article 210** covers the requirements for branch circuits.

**Article 215** covers the requirements for feeder circuits.

**Article 225** covers the requirements for outside branch circuits and feeders.

**Article 230** covers the requirements for services.

**240.2** defines current-limiting devices and coordination.

**240.4** requires conductors to be protected against overcurrent in accordance with their ampacity as specified in **310.15**. **240.4(B)** typically permits the next standard overcurrent protective device rating, per **240.6**, to be used if the ampacity of a conductor does not correspond with a standard rating (for overcurrent devices 800 amps or less).

**240.5** requires flexible cords, extension cords, and fixture wire to have overcurrent protection rated at their ampacities. Supplementary overcurrent protection is an acceptable method of protection. Additional acceptable branch circuit overcurrent protection conditions for conductors are covered in **240.5(B)**.

**240.6** provides the standard ampere ratings for fuses and inverse time circuit breakers.

**240.21** requires overcurrent protection in each ungrounded conductor to be located at the point where the conductors receive their supply, except as permitted in:

(B) Feeder Taps, (C) Transformer Secondary Conductors, (D) Service Conductors, (E) Busway Taps, (F) Motor Circuit Taps, and (G) Conductors from Generator Terminals.

**240.60** covers the general requirements for cartridge type fuses and fuseholders. This includes the requirements for 300V type fuses, non-interchangeable fuseholders, and fuse marking.

**240.83** covers the marking requirements for circuit breakers.

**240.85** covers the requirements for the application of straight (such as 480V) and slash rated (such as 480/277V) circuit breakers. Additional consideration of the circuit breakers' individual pole-interrupting capability for other than solidly grounded wye systems is indicated.

**240.86** covers the requirements for series rated combinations, where a circuit breaker with an interrupting rating lower than the available fault current can be applied provided it is properly protected by an acceptable overcurrent protective device on the line side of the circuit breaker. Additional considerations include marking and motor contribution.

**250.4** covers the requirements for grounding and bonding of electrical equipment. The bonding of equipment must provide an effective ground-fault current path. The grounding of equipment must provide a low-impedance circuit capable of carrying the maximum ground-fault current likely to be imposed on any part of the wiring system where a ground fault may occur.

**250.28** covers the requirements for the main bonding jumper.

**250.64** covers the installation requirements of the grounding electrode conductor. **250.66** covers the required size of the grounding electrode conductor.

**250.90** requires bonding to be provided where necessary to ensure electrical continuity and the capacity to conduct safely any fault current likely to be imposed. Bonding of services is covered in **250.92**. Bonding of other enclosures is covered in **250.96**. Bonding size and material is covered in **250.102**. Bonding of piping system and structural steel is covered in **250.104**.

**250.118** covers acceptable types of equipment grounding conductors. **250.120** covers the installation requirements for the equipment grounding conductor. **250.122** and **Table 250.122** cover the required minimum size for the equipment grounding conductor. **NOTE:** Where necessary to comply with **250.4**, the equipment grounding conductor may be required to be sized larger than shown in **Table 250.122**.

**Chapter 3** covers the requirements for wiring methods.

**310.15** covers the permitted ampacities for conductors.

**Article 404** covers the requirements for switches.

**Article 408** covers the requirements for panelboards and switchboards.

**430.32** covers the overload protection requirements for motor branch circuits. **430.52** covers the branch-circuit, short-circuit and ground-fault protection requirements for motor branch circuits.

**450.3** covers the overcurrent protection requirements for transformers.

**620.62** requires the overcurrent protective device for each elevator disconnecting means to be selective coordinated with any other supply side overcurrent protective device if multiple elevator circuits are fed from a single feeder.

For more detailed information, see the NE02<sup>®</sup> bulletin.

# Overcurrent Protective Device Ratings

---

In order for an overcurrent protective device to operate properly, the overcurrent protective device ratings must be properly selected. These ratings include **voltage**, **ampere** and **interrupting rating**. Of the three of the ratings, perhaps the most important and most often overlooked is the interrupting rating. If the interrupting rating is not properly selected, a serious hazard for equipment and personnel will exist. **Current limiting** can be considered as another overcurrent protective device rating, although not all overcurrent protective devices are required to have this characteristic. This will be discussed in more detail in Part IV, Component Protection.

## Voltage Rating

The voltage rating of the overcurrent protective device must be at least equal to or greater than the circuit voltage. The overcurrent protective device rating can be higher than the system voltage but never lower. For instance, a 600V fuse or circuit breaker can be used in a 208V circuit. One aspect of the voltage rating of an overcurrent protective device is a function of its capability to open a circuit under an overcurrent condition. Specifically, the voltage rating determines the ability of the overcurrent protective device to suppress and extinguish the internal arcing that occurs during the opening of an overcurrent condition. If an overcurrent protective device is used with a voltage rating lower than the circuit voltage, arc suppression and the ability to extinguish the arc will be impaired and, under some overcurrent conditions, the overcurrent protective device may not clear the overcurrent safely. The voltage rating is required to be marked on all overcurrent protective device labels.

NEC® 240.60 (A)(2) allows 300V type cartridge fuses to be permitted on single-phase line-to-neutral circuits supplied from 3-phase, 4 wire, solidly grounded neutral source where the line-to-neutral voltage does not exceed 300V. This allows 300V cartridge fuses to be used on single-phase 277V lighting circuits.

Per NEC® 240.85, a circuit breaker with a slash rating, such as 480Y/277V, can only be applied in a solidly grounded wye circuit where the nominal voltage of any conductor to ground does not exceed the lower of the two values and the nominal voltage between any two conductors does not exceed the higher value. Thus, a 480Y/277V circuit breaker could not be applied on a 480V corner grounded, because the voltage to ground exceeds 277 volts. It could not be used on 480V resistance grounded or ungrounded systems because they are not solidly grounded.

## Ampere Rating

Every overcurrent protective device has a specific ampere rating. In selecting the ampere rating of the overcurrent protective device, consideration must be given to the type of load and code requirements. The ampere rating of a fuse or circuit breaker normally should not exceed the current carrying capacity of the conductors. For instance, if a conductor is rated to carry 20A, a 20A fuse is the largest that should be used.

As a general rule, the ampere rating of a fuse or a circuit breaker is selected at 125% of the continuous load current. Since the conductors are generally selected at 125% of the continuous load current, the ampacity of the conductors is typically not exceeded. However, there are some specific circumstances in which the ampere rating is permitted to be greater than the current carrying capacity of the conductors. A typical example is the motor circuit; dual-element fuses generally are permitted to be sized up to 175% and an inverse time circuit breaker up to 250% of the motor full-load amperes.

NEC® 240.4(B) allows the next higher standard overcurrent protective device rating (above the ampacity of the conductors being protected) to be used for overcurrent protective devices 800A or less provided the conductor ampacity does not already correspond to a standard overcurrent protective device size and if certain other conditions are met.

NEC® 240.4(C) requires the ampacity of the conductor to be equal to or greater than the rating of the overcurrent protective device for overcurrent devices rated over 800A.

NEC® 240.4(D) requires the overcurrent protective device shall not exceed 15A for 14 AWG, 20A for 12 AWG, and 30A for 10 AWG copper; or 15A for 12 AWG and 25A for 10 AWG aluminum and copper-clad aluminum after any correction factors for ambient temperature and number of conductors have been applied.

NEC® 240.6 lists the standard ampere ratings for fuses and inverse time circuit breakers. Standard amperage sizes are 15, 20, 25, 30, 35, 40, 45, 50, 60, 70, 80, 90, 100, 110, 125, 150, 175, 200, 225, 250, 300, 350, 400, 450, 500, 600, 700, 800, 1000, 1200, 1600, 2000, 2500, 3000, 4000, 5000 and 6000. Additional standard ampere ratings for fuses are 1, 3, 6, 10 and 601. The use of non-standard ratings are permitted.

# Overcurrent Protective Device Ratings

## Interrupting Rating

NEC® Article 100 defines interrupting rating as:  
The highest current at rated voltage that a device is intended to interrupt under standard test conditions.

An overcurrent protective device must be able to withstand the destructive energy of short-circuit currents. If a fault current exceeds the interrupting rating of the overcurrent protective device, the device may actually rupture, causing additional damage.

The picture to the right illustrates how considerable damage can result if the interrupting rating of a protective device is exceeded by a short-circuit current. Thus, it is important when applying a fuse or circuit breaker to use one which can physically interrupt the largest potential short-circuit currents.



NEC® 110.9, requires equipment intended to interrupt current at fault levels to have an interrupting rating sufficient for the current that must be interrupted. This article emphasizes the difference between clearing fault level currents and clearing operating

currents. Protective devices such as fuses and circuit breakers are designed to clear fault currents and, therefore, must have short-circuit interrupting ratings sufficient for all available fault levels. Equipment such as contactors and switches have interrupting ratings for currents at other than fault levels, such as normal current overloads and locked rotor currents.

## Minimum Interrupting Rating

NEC® 240.60(C) states that the minimum interrupting rating for a branch-circuit cartridge fuse is 10,000A. NEC® 240.83(C) states that the minimum interrupting rating for a branch-circuit circuit breaker is 5,000A. The circuit breaker or fuse must be properly marked if the interrupting rating exceeds these respective minimum ratings. These minimum interrupting ratings and markings do not apply to supplemental protective devices such as glass tube fuses or supplemental protectors.

Modern current-limiting fuses, such as Class J, R, T and L have a high interrupting rating of 200,000A to 300,000A at rated voltage. Molded case circuit breakers typically come in a variety of interrupting ratings from 10,000A to 200,000A and are dependent upon the voltage rating. Typical incremental interrupting ratings for a single series of circuit breakers may be 14kA, 25kA, 65kA and 100kA at 480V. As interrupting rating of circuit breakers increases, so does the cost of the circuit breaker. Typically the circuit breaker that just meets the required available fault current is selected. However, this may be insufficient in the future if changes to the electrical system are made.

CURRENT INTERRUPTING RATING	MAX. R.M.S. AMPS.	VOLTS
	25,000 SYM.	600 AC
	35,000 SYM.	480 AC
	65,000 SYM.	240 AC

FOR 250 V.DC SERVICE USE OUTSIDE POLES ONLY

UND. LAB. INC. LIST.®  
CIRCUIT BREAKER  
3 POLE UNIT  
600 V.AC, 250 V.DC  
MADE IN USA

BUSS®  
LOW-PEAK®  
DUAL-ELEMENT  
TIME-DELAY  
FUSE  
LPJ-400SP  
600VAC OR LESS  
CURRENT LIMITING

LPJ-400SP

HRCT-J  
IR 200kA  
TYPE D

LISTED FUSE DL71-84  
IR 300kA AC  
LISTED SPECIAL PURPOSE

# Short-Circuit Currents and Interrupting Rating

To better understand interrupting rating and the importance of compliance with NEC® 110.9, consider these analogies

## Normal Current Operation

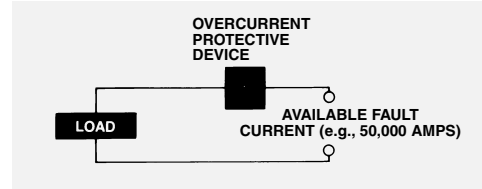
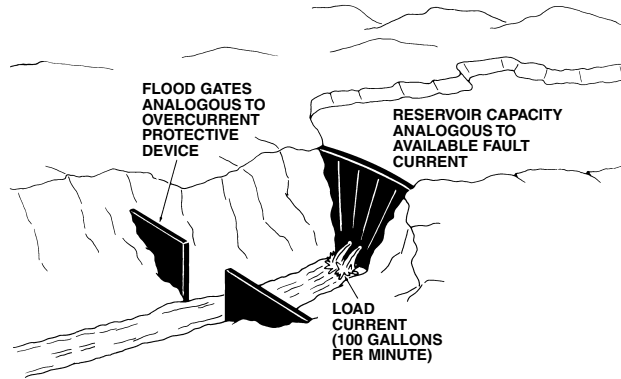

## Short-Circuit Operation with Inadequate Interrupting Rating

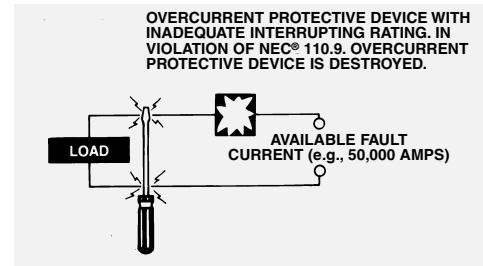
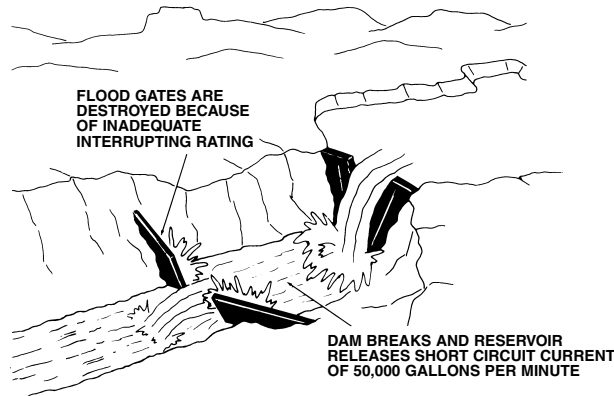

## Short-Circuit Operation with Adequate Interrupting Rating

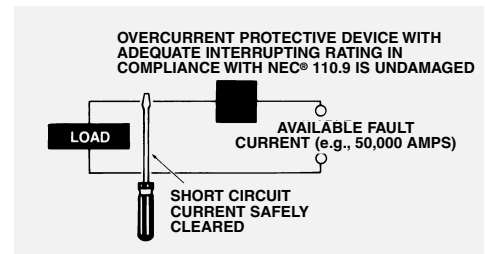
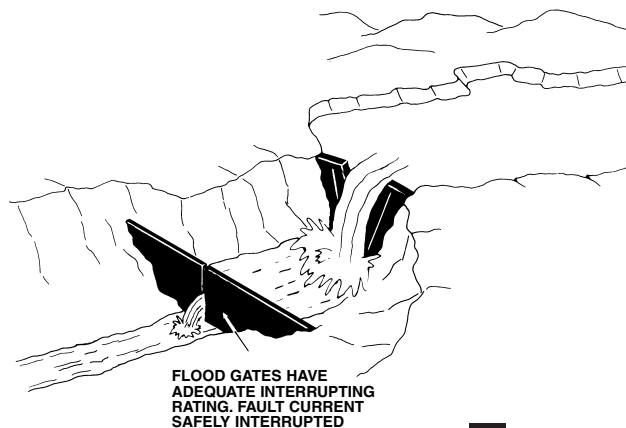

# Point-To-Point Method Of Short-Circuit Calculation

## Calculation Of Short-Circuit Currents — Point-To-Point Method.

Adequate interrupting rating and protection of electrical components are two essential aspects required by the NEC® 110.3(B), 110.9, 110.10, 240.1, 250.4, 250.90, 250.96, and Table 250.122 Note. The first step to ensure that system protective devices have the proper interrupting rating and provide component protection is to determine the available short-circuit currents. The application of the Point-To-Point method can be used to determine the available short-circuit currents with a reasonable degree of accuracy at various points for either 3φ or 1φ electrical distribution systems. The example shown here assumes unlimited primary short-circuit current (infinite bus).

### Basic Short-Circuit Calculation Procedure.

Procedure	Formula
<b>Step 1</b> Determine transf. full-load amperes from either: a) Name plate b) Tables 3A & 3B c) Formula	$3\phi \text{ transf. } I_{FLA} = \frac{KVA \times 1000}{E_{L-L} \times 1.732}$ $1\phi \text{ transf. } I_{FLA} = \frac{KVA \times 1000}{E_{L-L}}$
<b>Step 2</b> Find transformer multiplier See Note 3.	$\text{Multiplier} = \frac{100}{\text{Transf. \% Z}}$
<b>Step 3</b> Determine transf. let-through short-circuit current (Formula or Table 5) See Note 1 and Note 4.	$I_{SCA} = \text{Transf.}_{FLA} \times \text{multiplier}$
<b>Step 4</b> Calculate "f" factor.	$3\phi \text{ faults } f = \frac{1.732 \times L \times I_{L-L}}{C \times n \times E_{L-L}}$ $1\phi \text{ line-to-line (L-L) faults } f = \frac{2 \times L \times I_{L-L}}{C \times n \times E_{L-L}}$ $1\phi \text{ line-to-neutral (L-N) faults } f = \frac{2 \times L \times I_{L-N}^*}{C \times n \times E_{L-N}}$ <p>L = length (feet) of conduit to the fault. C = conductor constant. See Tables 1, 2. n = number of conductors per phase (Adjusts C value for parallel runs) I = available short-circuit current in amperes at beginning of circuit.</p>
<b>Step 5</b> Calculate "M" (multiplier) or take from Table 4.	$M = \frac{1}{1 + f}$
<b>Step 6</b> Compute the available short-circuit current (RMS symmetrical) See Note 1, Note 2, and Note 5	$I_{SCA} = I_{SCA} \times M$ at fault at beginning of circuit.

**† Note 1.** Motor short-circuit contribution, if significant, should be added at all fault locations throughout the system. A practical estimate of motor short-circuit contribution is to multiply the total motor full-load current in amperes by 4. Values of 4 to 6 are commonly accepted

**\* Note 2.** For single-phase center-tapped transformers, the L-N fault current is higher than the L-L fault current at the secondary terminals. The short-circuit current available (I) for this case in Step 4 should be adjusted at the transformer terminals as follows:

At L-N center tapped transformer terminals  
 $I_{L-N} = 1.5 \times I_{L-L}$  at Transformer Terminals

At some distance from the terminals, depending upon wire size, the L-N fault current is lower than the L-L fault current. The 1.5 multiplier is an approximation and will theoretically vary from 1.33 to 1.67. These figures are based on change in turns ratio between primary and secondary, infinite source available, zero feet from terminals of transformer, and 1.2 x %X and 1.5 x %R for L-N vs. L-L resistance and reactance values. Begin L-N calculations at transformer secondary terminals, then proceed point-to-point.

## Example Of 3-Phase Short-Circuit Calculation

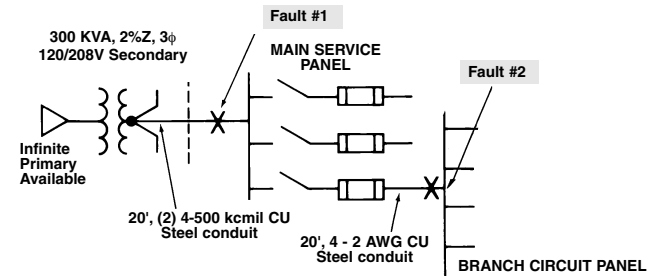

FAULT #1	
<b>Step 1</b>	$I_{FLA} = \frac{KVA \times 1000}{E_{L-L} \times 1.732} = \frac{300 \times 1000}{208 \times 1.732} = 833A$
<b>Step 2</b>	$\text{Multiplier} = \frac{100}{\dagger\dagger.9x \text{ Transf. \% Z}} = \frac{100}{1.8} = 55.55$
<b>Step 3</b>	$** I_{SCA (L-L-L)} = 833 \times 55.55 = 46,273$ 3-Phase Short-Circuit Current at Transformer Secondary
<b>Step 4</b>	$f = \frac{1.732 \times L \times I_{L-L-L}}{C \times n \times E_{L-L}} = \frac{1.732 \times 20 \times 46,273}{22,185 \times 2 \times 208} = .174$
<b>Step 5</b>	$M = \frac{1}{1 + f} = \frac{1}{1 + .174} = .852$ (See Table 4)
<b>Step 6</b>	$\dagger I_{SCA (L-L-L)} = 46,273 \times .852 = 39,425A$ 3-Phase Short Circuit Current at Fault #1
FAULT #2 (Use $I_{SCA (L-L-L)}$ at Fault #1 to calculate)	
<b>Step 4</b>	$f = \frac{1.732 \times 20 \times 39,425}{5,907 \times 1 \times 208} = 1.11$
<b>Step 5</b>	$M = \frac{1}{1 + f} = \frac{1}{1 + 1.11} = .474$ (See Table 4)
<b>Step 6</b>	$\dagger I_{SCA (L-L-L)} = 39,425 \times .474 = 18,687A$ 3-Phase Short-Circuit Current at Fault #2

\*\*The motor contribution and voltage variance should be accounted for at this point. See Notes 1 and 4.

†† Transformer %Z is multiplied by .9 to establish a worst case condition. See Note 3.

**Note 3:** The marked impedance values on transformers may vary ±10% from the actual values determined by ANSI / IEEE test. See U.L. Standard 1561. Therefore, multiply transformer %Z by .9. Transformers constructed to ANSI standards have a ± 7.5% impedance tolerance (two-winding construction).

**Note 4.** Utility voltages may vary ±10% for power, and ±5.8% for 120-volt lighting services. Therefore, for worst case conditions, multiply values as calculated in Step 3 by 1.1 and/or 1.058 respectively.

**Note 5:** The calculated short-circuit currents above represent the bolted fault values that approximate worst case conditions. Approximations of Bolted fault values as percentage of 3-Phase (L-L-L) bolted fault values are shown below.

Phase-Phase (L-L):	87%
Phase-Ground (L-G)	25-125% (Use 100% near transformer, 50% otherwise)
Phase-Neutral (L-N)	25-125% (Use 100% near transformer, 50% otherwise)

**Note 6:** Approximation of arcing fault values for sustained arcs as percentage of 3-Phase (L-L-L) bolted fault values are shown below.

3-Phase (L-L-L) Arcing Fault	89% (maximum)
Phase-Phase (L-L) Arcing Fault	74% (maximum)
Phase-Ground (L-G) Arcing Fault	38% (minimum)



# Point-To-Point Method Of Short-Circuit Calculation

## Calculation Of Short-Circuit Currents At Second Transformer In System.

Use the following procedure to calculate the level of fault current at the secondary of a second, downstream transformer in a system when the level of fault current at the transformer primary is known.

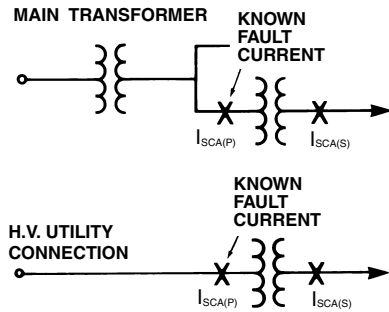

## Procedure For Second Transformer in System

Procedure	Formula
<b>Step A</b> Calculate "f" ( $I_{SCA(P)}$ , known).	$f = \frac{I_{SCA(P)} \times V_P \times 1.732 (\%Z)}{100,000 \times KVA}$ $f = \frac{I_{SCA(P)} \times V_P \times (\%Z)}{100,000 \times KVA}$
<b>Step B</b> Calculate "M" (multiplier) or take from Table 4.	$M = \frac{1}{1 + f}$
<b>Step C</b> Calculate short-circuit current at secondary of transformer. (See Note 1 under "Basic Procedure")	$I_{SCA(S)} = \frac{V_P}{V_S} \times M \times I_{SCA(P)}$

$I_{SCA(P)}$  = Available fault current at transformer primary.  
 $I_{SCA(S)}$  = Available fault current at transformer secondary.  
 $V_P$  = Primary voltage L-L.  
 $V_S$  = Secondary voltage L-L.  
 KVA = KVA rating of transformer.  
 %Z = Percent impedance of transformer.  
 Note: To calculate fault level at the end of a conductor run, follow Steps 4, 5, and 6 of Basic Procedure.

**Table 1. "C" Values for Busway**

Ampacity	Busway				
	Plug-In		Feeder		
	Copper	Aluminum	Copper	Aluminum	Copper
225	28700	23000	18700	12000	—
400	38900	34700	23900	21300	—
600	41000	38300	36500	31300	—
800	46100	57500	49300	44100	—
1000	69400	89300	62900	56200	15600
1200	94300	97100	76900	69900	16100
1350	119000	104200	90100	84000	17500
1600	129900	120500	101000	90900	19200
2000	142900	135100	134200	125000	20400
2500	143800	156300	180500	166700	21700
3000	144900	175400	204100	188700	23800
4000	—	—	277800	256400	—

Note: These values are equal to one over the impedance per foot for impedance in a survey of industry.

**Table 2. "C" Values for Conductors**

Copper AWG or kcmil	Three Single Conductors Conduit						Three-Conductor Cable Conduit					
	Steel		Nonmagnetic				Steel		Nonmagnetic			
	600V	5kV	600V	5kV	15kV	600V	5kV	15kV	600V	5kV	15kV	
14	389	-	-	389	-	-	389	-	-	-	-	
12	617	-	-	617	-	-	617	-	-	-	-	
10	981	-	-	982	-	-	982	-	-	-	-	
8	1557	1551	-	1559	1555	-	1559	1557	-	1560	1558	
6	2425	2406	2389	2430	2418	2407	2431	2425	2415	2433	2428	
4	3806	3751	3696	3826	3789	3753	3830	3812	3779	3838	3823	
3	4774	4674	4577	4811	4745	4679	4820	4785	4726	4833	4803	
2	5907	5736	5574	6044	5926	5809	5989	5930	5828	6087	6023	
1	7293	7029	6759	7493	7307	7109	7454	7365	7189	7579	7507	
1/0	8925	8544	7973	9317	9034	8590	9210	9086	8708	9473	9373	
2/0	10755	10062	9390	11424	10878	10319	11245	11045	10500	11703	11529	
3/0	12844	11804	11022	13923	13048	12360	13656	13333	12613	14410	14119	
4/0	15082	13606	12543	16673	15351	14347	16392	15890	14813	17483	17020	
250	16483	14925	13644	18594	17121	15866	18311	17851	16466	19779	19352	
300	18177	16293	14769	20868	18975	17409	20617	20052	18319	22525	21938	
350	19704	17385	15678	22737	20526	18672	22646	21914	19821	24904	24126	
400	20566	18235	16366	24297	21786	19731	24253	23372	21042	26916	26044	
500	22185	19172	17492	26706	23277	21330	26980	25449	23126	30096	28712	
600	22965	20567	17962	28033	25204	22097	28752	27975	24897	32154	31258	
750	24137	21387	18889	29735	26453	23408	31051	30024	26933	34605	33315	
1,000	25278	22539	19923	31491	28083	24887	33864	32689	29320	37197	35749	

Note: These values are equal to one over the impedance per foot and based upon resistance and reactance values found in IEEE Std 241-1990 (Gray Book), IEEE Recommended Practice for Electric Power Systems in Commercial Buildings & IEEE Std 242-1986 (Buff Book), IEEE Recommended Practice for Protection and Coordination of Industrial and Commercial Power Systems. Where resistance and

# Point-To-Point Method Of Short-Circuit Calculation

**Table 4. "M" (Multiplier)\***

f	M	f	M
0.01	0.99	1.50	0.40
0.02	0.98	1.75	0.36
0.03	0.97	2.00	0.33
0.04	0.96	2.50	0.29
0.05	0.95	3.00	0.25
0.06	0.94	3.50	0.22
0.07	0.93	4.00	0.20
0.08	0.93	5.00	0.17
0.09	0.92	6.00	0.14
0.10	0.91	7.00	0.13
0.15	0.87	8.00	0.11
0.20	0.83	9.00	0.10
0.25	0.80	10.00	0.09
0.30	0.77	15.00	0.06
0.35	0.74	20.00	0.05
0.40	0.71	30.00	0.03
0.50	0.67	40.00	0.02
0.60	0.63	50.00	0.02
0.70	0.59	60.00	0.02
0.80	0.55	70.00	0.01
0.90	0.53	80.00	0.01
1.00	0.50	90.00	0.01
1.20	0.45	100.00	0.01

$$* M = \frac{1}{1 + f}$$

Table 5 Notes:

\* Single phase values are L-N values at transformer terminals. These figures are based on change in turns ratio between primary and secondary, 100,000 KVA primary, zero feet from terminals of transformer, 1.2 (%X) and 1.5 (%R) multipliers for L-N vs. L-L reactance and resistance values and transformer X/R ratio = 3.

\*\* Three-phase short-circuit currents based on "infinite" primary.

†† UL listed transformers 25 KVA or greater have a ±10% impedance tolerance. Transformers constructed to ANSI standards have a ± 7.5% impedance tolerance (two-winding construction). Short-circuit amps reflect a "worst case" condition (-10%).

† Fluctuations in system voltage will affect the available short-circuit current. For example, a 10% increase in system voltage will result in a 10% increase in the available short-circuit currents shown in the table.

**Table 5. Short-Circuit Currents Available from Various Size Transformers**

(Based upon actual field nameplate data, published information, or from utility transformer worst case impedance)

Voltage and Phase	KVA	Full Load Amps	% Impedance†† (nameplate)	Short Circuit Amps†
120/240 1 ph.*	25	104	1.5	12175
	37.5	156	1.5	18018
	50	208	1.5	23706
	75	313	1.5	34639
	100	417	1.6	42472
	167	696	1.6	66644
120/208 3 ph.**	45	125	1.0	13879
	75	208	1.0	23132
	112.5	312	1.11	31259
	150	416	1.07	43237
	225	625	1.12	61960
	300	833	1.11	83357
	500	1388	1.24	124364
	750	2082	3.50	66091
	1000	2776	3.50	88121
	1500	4164	3.50	132181
	2000	5552	4.00	154211
	2500	6940	4.00	192764
277/480 3 ph.**	75	90	1.0	10035
	112.5	135	1.0	15053
	150	181	1.20	16726
	225	271	1.20	25088
	300	361	1.20	33451
	500	602	1.30	51463
	750	903	3.50	28672
	1000	1204	3.50	38230
	1500	1806	3.50	57345
	2000	2408	4.00	66902
	2500	3011	4.00	83628

Aluminum							Three-Conductor Cable					
AWG or kcmil	Three Single Conductors or Conduit			Nonmagnetic			Steel Conduit			Nonmagnetic		
	600V	5kV	15kV	600V	5kV	15kV	600V	5kV	15kV	600V	5kV	15kV
14	237	-	-	237	-	-	237	-	-	237	-	-
12	376	-	-	376	-	-	376	-	-	376	-	-
10	599	-	-	599	-	-	599	-	-	599	-	-
8	951	950	-	952	951	-	952	951	-	952	952	-
6	1481	1476	1472	1482	1479	1476	1482	1480	1478	1482	1481	1479
4	2346	2333	2319	2350	2342	2333	2351	2347	2339	2353	2350	2344
3	2952	2928	2904	2961	2945	2929	2963	2955	2941	2966	2959	2949
2	3713	3670	3626	3730	3702	3673	3734	3719	3693	3740	3725	3709
1	4645	4575	4498	4678	4632	4580	4686	4664	4618	4699	4682	4646
1/0	5777	5670	5493	5838	5766	5646	5852	5820	5717	5876	5852	5771
2/0	7187	6968	6733	7301	7153	6986	7327	7271	7109	7373	7329	7202
3/0	8826	8467	8163	9110	8851	8627	9077	8981	8751	9243	9164	8977
4/0	10741	10167	9700	11174	10749	10387	11185	11022	10642	11409	11277	10969
250	12122	11460	10849	12862	12343	11847	12797	12636	12115	13236	13106	12661
300	13910	13009	12193	14923	14183	13492	14917	14698	13973	15495	15300	14659
350	15484	14280	13288	16813	15858	14955	16795	16490	15541	17635	17352	16501
400	16671	15355	14188	18506	17321	16234	18462	18064	16921	19588	19244	18154
500	18756	16828	15657	21391	19503	18315	21395	20607	19314	23018	22381	20978
600	20093	18428	16484	23451	21718	19635	23633	23196	21349	25708	25244	23295
750	21766	19685	17686	25976	23702	21437	26432	25790	23750	29036	28262	25976
1,000	23478	21235	19006	28779	26109	23482	29865	29049	26608	32938	31920	29135

reactance values differ or are not available, the Buff Book values have been used. The values for reactance in determining the C Value at 5 KV & 15 KV are from the Gray Book only (Values for 14-10 AWG at 5 kV and 14-8 AWG at 15 kV are not available and values for 3 AWG have been approximated).

## MAIN DISTRIBUTION PANEL "MDP"

800 AMPERE MLO  
120/208 VOLT, 3 PHASE, 4 WIRE

ITEM	EQUIPMENT	SWITCH-FUSE	COMMENTS
1	800 A 120/208 V, 3Ø 4 W INCOMING LINE SECTION		
2	MAIN SWITCH	800/800 3P	BOLTED PRESSURE SWITCH KRP-C FUSES INSTALLED BY E.C.
3	LTNG PNL	"LPA" 200/200 3P	LPN-RK FUSES INSTALLED BY E.C.
4	LTNG PNL	"LPC" 200/150 3P	SAME AS ITEM 3
5	LTNG PNL	"LPB" 100/100 3P	SAME AS ITEM 3
6	ROOFTOP UNIT AC-1	100/90 3P	SAME AS ITEM 3
7	ROOFTOP UNIT AC-2	100/70 3P	SAME AS ITEM 3
8	SPARE	100/ 3P	NO FUSES REQUIRED
9	SPARE	200/ 3P	NO FUSES REQUIRED

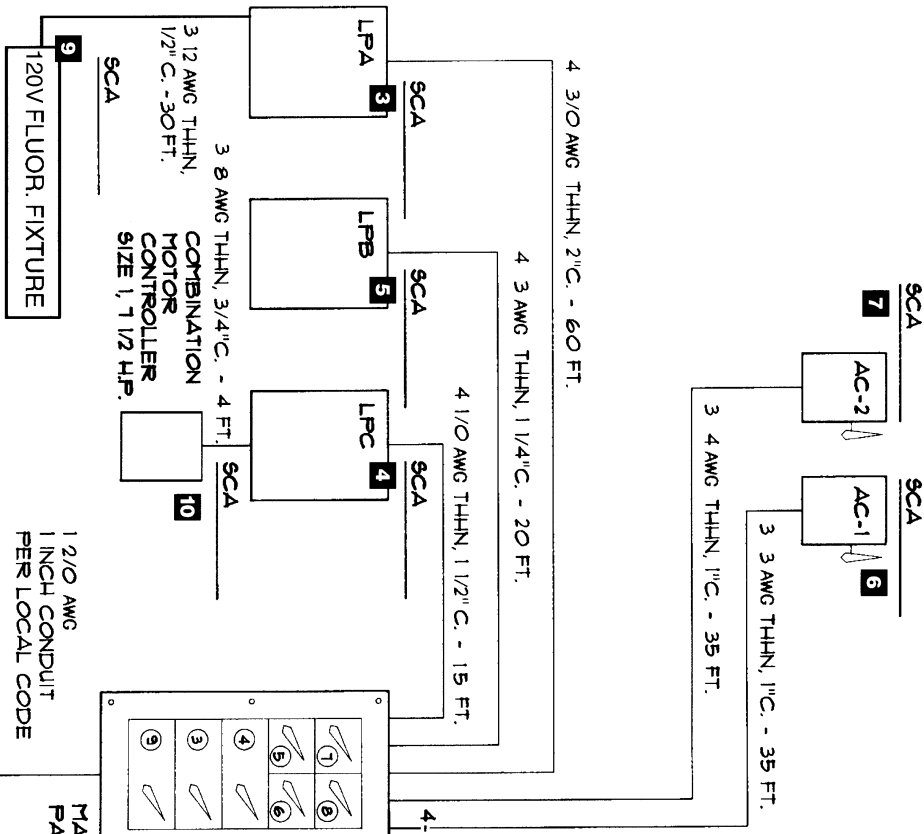

NOTE: SHORT CIRCUIT AMPERES (SCA) IN RMS VALUES UNLESS OTHERWISE NOTED.  
NOTE: ALL CONDUCTORS COPPER IN STEEL RACEWAY.

NOTE: FLUORESCENT FIXTURES INCLUDE HLR HOLDERS WITH GLR-2 FUSES.

8 SCA  
E.C. SHALL FURNISH & INSTALL COMBINATION 800 A, 120/208 V, 3Ø, 4W C/T CABINET & METER FITTING, NEMA 3R CONSTRUCTION ON EXTERIOR WALL PER UTILITY REQUIREMENTS.

<b>9ADDLEBROOK CENTER</b>	
SCALE: NTS	APPROVED BY: RCM
DATE:	DRAWN BY: RCM
DRAWING NUMBER:	

# Work Sheet Problem—Main Distribution Panel

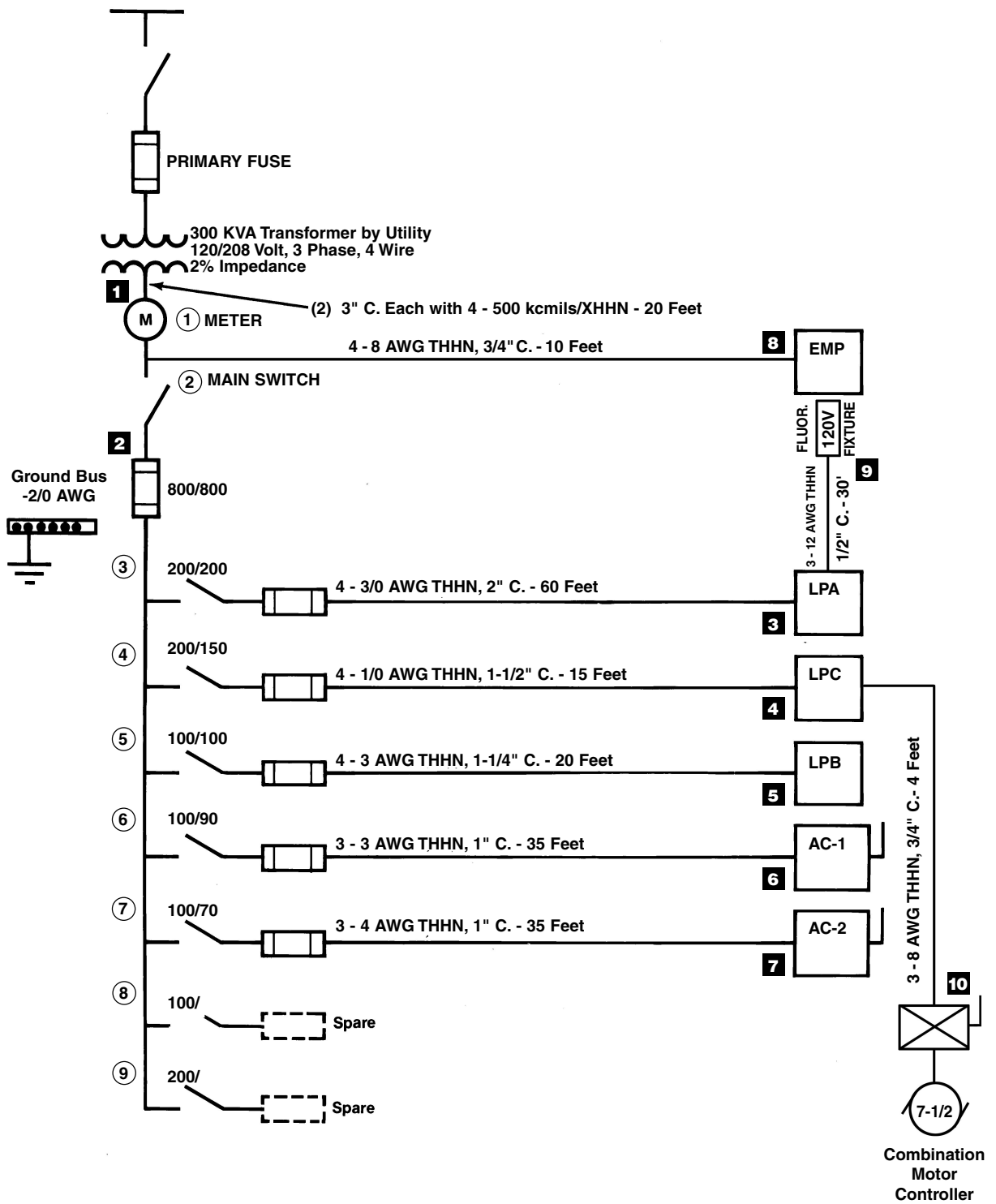

Note: Assume steel conduit.

# Short-Circuit Calculations - Worksheet

---

## (1) Transformer (Secondary Terminals – Assuming Infinite Primary)

Find: Transformer Full-Load Amperes -  $I_{FLA}$  (3 Phase):

$I_{FLA} =$

Find: Multiplier – “M”

M =

Calculate: Short-Circuit Current (SCA)

SCA =

SCA with voltage variance =

Motor Contribution\* =

\* Note: Calculate additional motor short-circuit contribution. Assume 50% (400A) of the total load is from all motors. Multiply total motor FLA by 4 (400 x 4 = 1,600A). In theory, the additional motor short-circuit contribution should be calculated at all points in the system, and may vary depending upon the location.

SCA with voltage variance and motor contribution =

## (2) MDP

Short-Circuit Current at beginning of run (Transformer Secondary Terminals with voltage variance)

= \_\_\_\_\_

Find: “f” factor

f =

Find: Multiplier - “M”

M =

Calculate: Short-Circuit Current (SCA)

SCA with voltage variance =

Motor Contribution =

SCA with voltage variance and motor contribution =

## (3) LPA

Short-Circuit Current at beginning of run (MDP with voltage variance) = \_\_\_\_\_

Find: “f” factor

f =

Find: Multiplier - “M”

M =

Calculate: Short-Circuit Current (SCA)

SCA with voltage variance =

Motor Contribution =

SCA with voltage variance and motor contribution =

## (4) LPC

Short-Circuit Current at beginning of run (MDP with voltage variance) = \_\_\_\_\_

Find: “f” factor

f =

Find: Multiplier - “M”

M =

Calculate: Short-Circuit Current (SCA)

SCA with voltage variance =

Motor Contribution =

SCA with voltage variance and motor contribution =

# Short-Circuit Calculations - Worksheet

---

## (5) LPB

Short-Circuit Current at beginning of run (MDP with voltage variance) = \_\_\_\_\_

Find: "f" factor

f =

Find: Multiplier - "M"

M =

Calculate: Short-Circuit Current (SCA)

SCA with voltage variance =

Motor Contribution =

SCA with voltage variance and motor contribution =

## (6) AC-1

Short-Circuit Current at beginning of run (MDP with voltage variance) = \_\_\_\_\_

Find: "f" factor

f =

Find: Multiplier - "M"

M =

Calculate: Short-Circuit Current (SCA)

SCA with voltage variance =

Motor Contribution =

SCA with voltage variance and motor contribution =

## (7) AC-2

Short-Circuit Current at beginning of run (MDP with voltage variance) = \_\_\_\_\_

Find: "f" factor

f =

Find: Multiplier - "M"

M =

Calculate: Short-Circuit Current (SCA)

SCA with voltage variance =

Motor Contribution =

SCA with voltage variance and motor contribution =

# Short-Circuit Calculations - Worksheet

---

## **(8) EMP**

Short-Circuit Current at beginning of run (MDP with voltage variance) = \_\_\_\_\_

Find: “f” factor

f =

Find: Multiplier - “M”

M =

Calculate: Short-Circuit Current (SCA)

SCA<sub>with voltage variance</sub> =

Motor Contribution =

SCA<sub>with voltage variance and motor contribution</sub> =

## **(9) Fluorescent Fixture**

Short-Circuit Current at beginning of run (LPA with voltage variance) = \_\_\_\_\_

Find: “f” factor

f =

Find: Multiplier - “M”

M =

Calculate: Short-Circuit Current (SCA)

SCA<sub>with voltage variance</sub> =

\*Ignore motor contribution for this step

## **(10) Combination Motor Controller**

Short-Circuit Current at beginning of run (LPC with voltage variance) = \_\_\_\_\_

Find: “f” factor

f =

Find: Multiplier - “M”

M =

Calculate: Short-Circuit Current (SCA)

SCA<sub>with voltage variance</sub> =

Motor Contribution =

SCA<sub>with voltage variance and motor contribution</sub> =

# NEC® 110.10, Current Limitation, and Devices

**NEC® 110.10** states “The overcurrent protective devices, the total impedance, the component short-circuit current ratings, and other characteristics of the circuit to be protected shall be selected and coordinated to permit the circuit protective devices used to clear a fault to do so without extensive damage to the electrical components of the circuit. This fault shall be assumed to be either between two or more of the circuit conductors, or between any circuit conductor and the grounding conductor or enclosing metal raceway. Listed products applied in accordance with their listing shall be considered to meet the requirements of this section.”

This requires that overcurrent protective devices, such as fuses and circuit breakers be selected in such a manner that the short-circuit current ratings of the system components will not be exceeded should a short circuit occur. The “short-circuit current rating” is the maximum short-circuit current that a component can safely withstand. Failure to limit the fault current within the short-circuit current rating may result in component destruction under short-circuit conditions.

The last sentence of NEC® 110.10 emphasizes the requirement to thoroughly review the product standards and to apply components within the short-circuit current ratings in these standards. Simply, selecting overcurrent protective devices that have an adequate interrupting rating per NEC® 110.9, does not assure protection of electrical system components. To properly comply with NEC® 110.10, current limiting overcurrent protective devices may be required.

### Current Limitation

The clearing time for an overcurrent protective device can vary depending upon the type of device used. Many circuit breakers require one-half (½) to three cycles to open as shown in the figure to the right.

However, other devices are tested, listed, and marked as current-limiting, such as the Bussmann® Low-Peak® Fuses. To be listed as current limiting several requirements must be met.

### NEC® 240.2 offers the following definition of a current-limiting overcurrent protective device:

“A current-limiting overcurrent protective device is a device that, when interrupting currents in its current-limiting range, will reduce the current flowing in the faulted circuit to a magnitude substantially less than that obtainable in the same circuit if the device were replaced with a solid conductor having comparable impedance.”

A current-limiting overcurrent protective device is one that cuts off a fault current, within its current-limiting range, in less than one-half cycle. See figure to right. It thus prevents short-circuit currents from building up to their full available values. In practice, an overcurrent protective device can be determined to be current limiting if it is listed and marked as current limiting in accordance with the listing standard. It is important to note that not all devices have the same degree of current limitation, some devices are more current limiting than others. The degree of current-limitation can be determined from the let-through charts.

Greatest damage can occur to components in the first half-cycle. Heating of components to very high temperatures can cause deterioration of insulation, or even vaporization of conductors. Tremendous magnetic forces between conductors can crack insulators and loosen or rupture bracing structures.

### Current-Limiting Overcurrent Devices

The degree of current-limitation of an overcurrent protective device, such as a current-limiting fuse, depends upon the size, type of fuse, and in general, upon the available short-circuit current which can be delivered by the electrical system. The current-limitation of fuses can be determined by let-through charts. Fuse let-through charts are plotted from actual test data. The fuse curves represent the cutoff value of the prospective available short-circuit current under the given circuit conditions. Each type or class of fuse has its own family of let-through curves.

Prior to using the Let-Through Charts, it must be determined what let-through data is pertinent to equipment withstand ratings. Equipment withstand ratings can be described as:

### How Much Fault Current can the equipment handle, and for How Long?

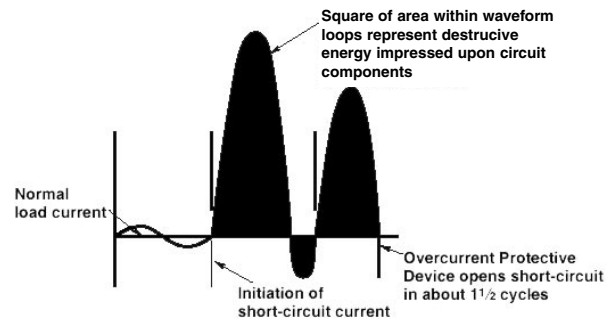

ACTION OF NON-CURRENT-LIMITING OVERCURRENT PROTECTIVE DEVICE

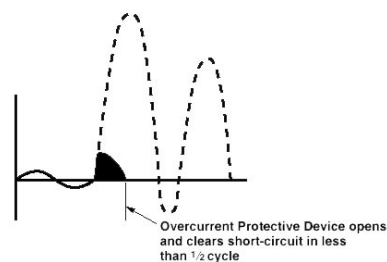

ACTION OF CURRENT-LIMITING OVERCURRENT PROTECTIVE DEVICE



# Let-Through Charts

The most important data which can be obtained from the Let-Through Charts and their physical effects are the following:

- A. Peak let-through current – the square of which relates to maximum mechanical forces
- B. Apparent prospective RMS symmetrical let-through current – the square of which relates to the thermal energy

### How to Use the Let-Through Charts

This is a typical example showing the short-circuit current available (86,000 amperes) to an 800 ampere circuit, an 800 ampere Bussmann® LOW-PEAK® current-limiting, time-delay fuse, and the let-through data of interest.

Using the example given, one can determine the pertinent let-through data for the Bussmann® KRP-C800SP ampere LOW-PEAK® fuse.

#### A. Determine the peak let-through current.

- Step 1.** Enter the chart on the prospective short-circuit current scale at 86,000 amperes (point A) and proceed vertically until the 800 ampere fuse curve is intersected.
- Step 2.** Follow horizontally until the instantaneous peak let-through current scale is intersected (point D).
- Step 3.** Read the peak let-through current as 49,000 amperes. (If a fuse had not been used, the peak current would have been 198,000 amperes (point C).)

#### B. Determine the apparent prospective RMS symmetrical let-through current.

- Step 1.** Enter the chart on the prospective short-circuit current scale at 86,000 amperes (point A) and proceed vertically until the 800 ampere fuse curve is intersected.
- Step 2.** Follow horizontally until line A-B is intersected.
- Step 3.** Proceed vertically down to the prospective short-circuit current (point B).
- Step 4.** Read the apparent prospective RMS symmetrical let-through current as 21,000 amperes. (the RMS symmetrical let-through current would be 86,000 amperes if there were no fuse in the circuit.)

Most electrical equipment has a withstand rating that is defined in terms of an RMS symmetrical-short-circuit current, and in some cases, peak let-through current. These values have been established through short-circuit testing of that equipment according to an accepted industry standard. Or, as is the case with conductors, the withstand rating is based on a physics formula and is also expressed in an RMS short-circuit current. If both the let-through currents ( $I_{RMS}$  and  $I_p$ ) of the current-limiting overcurrent protective device and the time it takes to clear the fault are less than the withstand rating of the

### 800 Ampere LOW-PEAK® Current-Limiting Time-Delay Fuse and Associated Let-Through Data

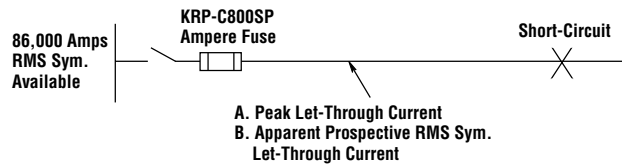

### Current-Limitation Curves — Bussmann® LOW-PEAK® Time-Delay Fuse KRP-C-800SP

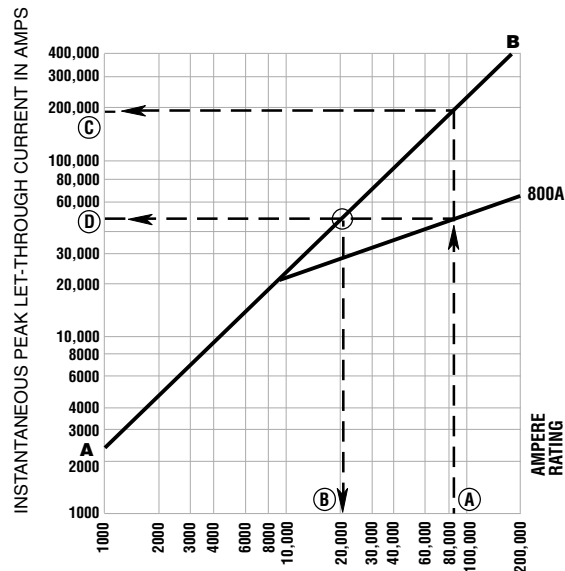

PROSPECTIVE SHORT-CIRCUIT CURRENT – SYMMETRICAL RMS AMPS

- (A)  $I_{RMS}$  Available = 86,000 Amperes
- (B)  $I_{RMS}$  Let-Through = 21,000 Amperes
- (C)  $I_p$  Available = 198,000 Amperes
- (D)  $I_p$  Let-Through = 49,000 Amperes

electrical component, then that component will be protected from short-circuit damage.

Let-through charts and tables for Bussmann® KRP-C, LPJ, LPN-RK, LPS-RK, FRN-R, FRS-R, JJJ, and JJS fuses are shown on pages 17-20.

# Let-Through Charts

## LOW-PEAK® YELLOW Class L Time-Delay Fuses KRP-C\_SP

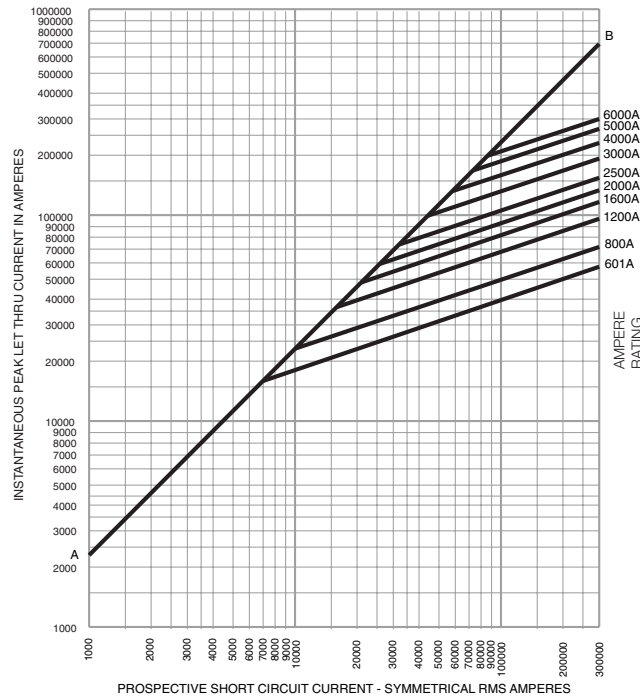

## KRP-C\_SP Fuse – RMS Let-Through Currents (kA)

Prosp. Short C.C.	Fuse Size									
	601	800	1200	1600	2000	2500	3000	4000	5000	6000
	I <sub>RMS</sub>	I <sub>RMS</sub>	I <sub>RMS</sub>	I <sub>RMS</sub>	I <sub>RMS</sub>	I <sub>RMS</sub>	I <sub>RMS</sub>	I <sub>RMS</sub>	I <sub>RMS</sub>	I <sub>RMS</sub>
5,000	5	5	5	5	5	5	5	5	5	5
10,000	8	10	10	10	10	10	10	10	10	10
15,000	9	12	15	15	15	15	15	15	15	15
20,000	10	13	17	20	20	20	20	20	20	20
25,000	11	14	19	22	25	25	25	25	25	25
30,000	11	14	20	24	27	30	30	30	30	30
35,000	12	15	21	25	29	35	35	35	35	35
40,000	13	16	22	26	30	35	40	40	40	40
50,000	14	17	23	28	32	37	50	50	50	50
60,000	15	18	25	30	34	40	49	60	60	60
70,000	15	19	26	32	36	42	52	62	70	70
80,000	16	20	27	33	38	44	54	65	76	80
90,000	17	21	29	34	39	45	56	67	79	90
100,000	17	22	30	36	41	47	58	70	81	100
150,000	20	25	34	41	47	54	67	80	93	104
200,000	22	27	37	45	51	59	73	87	102	114
250,000	24	29	40	49	55	64	79	94	110	123
300,000	25	31	43	52	59	68	84	100	117	30

Note: For I<sub>RMS</sub> value at 300,000 amperes, consult Factory.

## LOW-PEAK® YELLOW Class J, Dual-Element Time-Delay Fuses LPJ\_SP

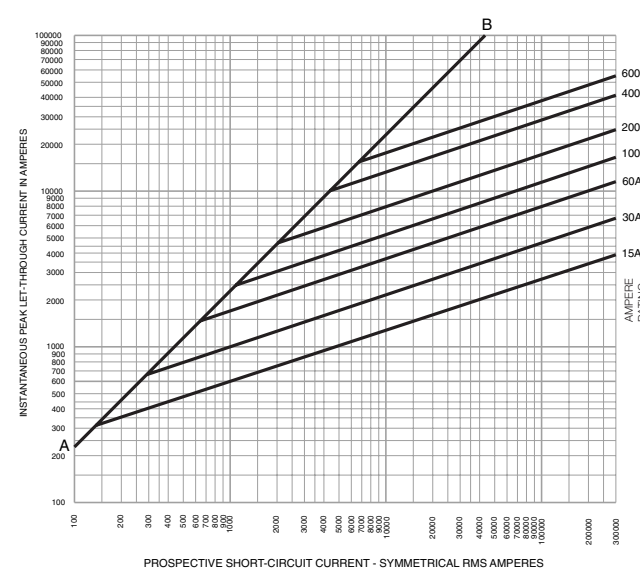

## LPJ\_SP Fuse – RMS Let-Through Currents (kA)

Prosp. Short C.C.	Fuse Size						
	15	30	60	100	200	400	600
	I <sub>RMS</sub>	I <sub>RMS</sub>	I <sub>RMS</sub>	I <sub>RMS</sub>	I <sub>RMS</sub>	I <sub>RMS</sub>	I <sub>RMS</sub>
1,000	1	1	1	1	1	1	1
3,000	1	1	1	2	2	3	3
5,000	1	1	1	2	3	5	5
10,000	1	1	2	2	4	6	8
15,000	1	1	2	3	4	7	9
20,000	1	1	2	3	4	7	10
25,000	1	1	2	3	5	8	10
30,000	1	1	2	3	5	8	11
35,000	1	1	2	4	5	9	12
40,000	1	2	3	4	6	9	12
50,000	1	2	3	4	6	10	13
60,000	1	2	3	4	6	11	14
80,000	1	2	3	5	7	12	15
100,000	1	2	4	5	8	12	17
150,000	1	2	4	6	9	14	19
200,000	2	3	4	6	9	16	21
250,000	2	3	5	7	10	17	23
300,000	2	3	5	7	11	18	24

Note: For I<sub>RMS</sub> value at 300,000 amperes, consult Factory.

# Let-Through Charts

**LOW-PEAK® YELLOW Class RK1 Dual-Element Time-Delay Fuses  
LPN-RK\_SP**

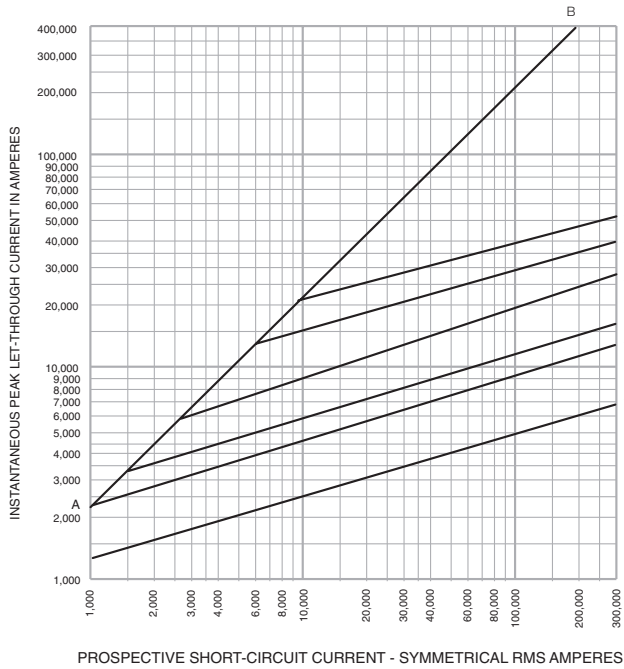

**LPN-RK\_SP – RMS Let-Through Currents (kA)**

Prosp. Short C.C.	Fuse Size					
	30	60	100	200	400	600
	$I_{RMS}$	$I_{RMS}$	$I_{RMS}$	$I_{RMS}$	$I_{RMS}$	$I_{RMS}$
1,000	1	1	1	1	1	1
2,000	1	1	2	2	2	2
3,000	1	1	2	3	3	3
5,000	1	2	2	3	5	5
10,000	1	2	3	4	7	9
15,000	1	2	3	5	8	11
20,000	1	3	3	5	8	11
25,000	1	3	3	5	9	12
30,000	2	3	4	6	9	12
35,000	2	3	4	6	10	13
40,000	2	3	4	6	10	13
50,000	2	3	4	7	11	14
60,000	2	3	4	7	11	16
70,000	2	3	4	7	12	16
80,000	2	4	5	8	12	16
90,000	2	4	5	7	13	17
100,000	2	4	5	8	13	17
150,000	2	4	6	9	15	19
200,000	3	5	6	11	16	20
250,000	3	5	7	11	17	21
300,000	3	6	7	12	18	22

**LOW-PEAK® YELLOW Class RK1 Dual-Element Time-Delay Fuses  
LPS-RK\_SP**

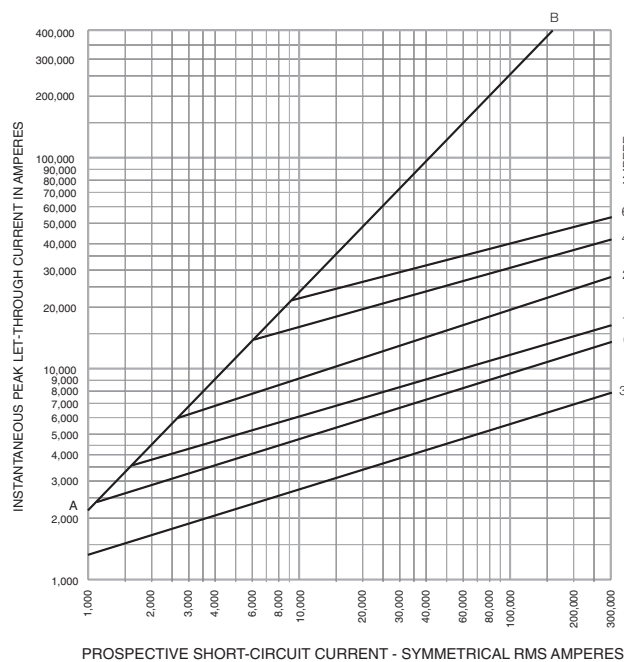

**LPS-RK\_SP – RMS Let-Through Currents (kA)**

Prosp. Short C.C.	Fuse Size					
	30	60	100	200	400	600
	$I_{RMS}$	$I_{RMS}$	$I_{RMS}$	$I_{RMS}$	$I_{RMS}$	$I_{RMS}$
1,000	1	1	1	1	1	1
2,000	1	1	2	2	2	2
3,000	1	1	2	3	3	3
5,000	1	2	2	3	5	5
10,000	1	2	3	4	7	10
15,000	1	2	3	5	8	11
20,000	2	3	3	5	9	12
25,000	2	3	4	6	9	12
30,000	2	3	4	6	10	13
35,000	2	3	4	6	10	13
40,000	2	3	4	6	10	14
50,000	2	3	5	7	11	15
60,000	2	4	5	7	12	15
70,000	2	4	5	8	13	16
80,000	2	4	5	8	13	16
90,000	2	4	5	8	13	17
100,000	2	4	6	9	14	17
150,000	3	5	6	10	15	19
200,000	3	5	7	11	16	21
250,000	3	6	7	12	17	22
300,000	3	6	7	12	18	23

# Let-Through Charts

## FUSETRON® Class RK5 Dual-Element Time-Delay Fuses FRN-R

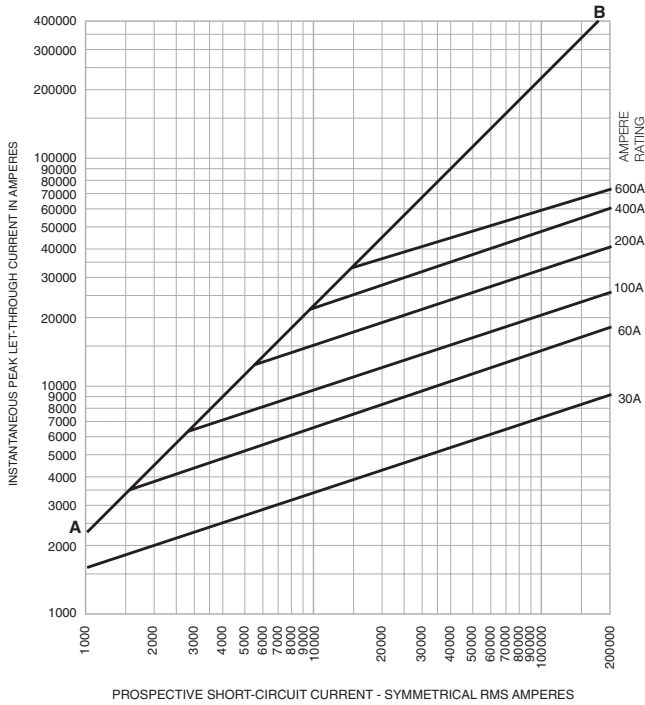

## FRN-R – RMS Let-Through Currents (kA)

Prosp. Short C.C.	Fuse Size					
	30	60	100	200	400	600
	I <sub>RMS</sub>	I <sub>RMS</sub>	I <sub>RMS</sub>	I <sub>RMS</sub>	I <sub>RMS</sub>	I <sub>RMS</sub>
5,000	1	2	3	5	5	5
10,000	2	3	4	7	10	10
15,000	2	3	5	8	11	15
20,000	2	4	5	8	12	16
25,000	2	4	6	9	13	17
30,000	2	4	6	10	14	18
35,000	2	4	6	10	15	19
40,000	2	5	7	11	15	20
50,000	3	5	7	11	17	21
60,000	3	5	8	12	18	22
70,000	3	6	8	13	19	23
80,000	3	6	8	13	19	24
90,000	3	6	9	14	20	25
100,000	3	6	9	14	21	26
150,000	4	7	10	16	24	29
200,000	4	8	11	18	26	32

## FUSETRON® Class RK5 Dual-Element Time-Delay Fuses FRS-R

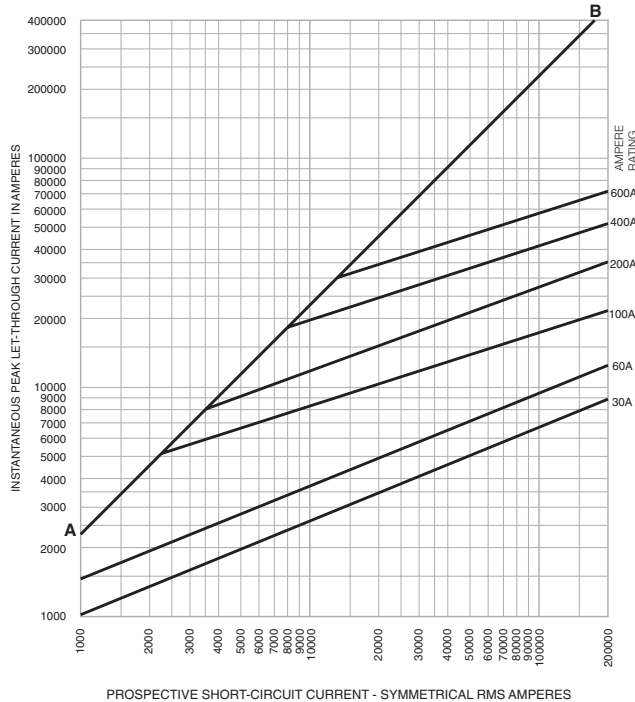

## FRS-R – RMS Let-Through Currents (kA)

Prosp. Short C.C.	Fuse Size					
	30	60	100	200	400	600
	I <sub>RMS</sub>	I <sub>RMS</sub>	I <sub>RMS</sub>	I <sub>RMS</sub>	I <sub>RMS</sub>	I <sub>RMS</sub>
5,000	1	1	3	4	5	5
10,000	1	2	4	5	9	10
15,000	1	2	4	6	10	14
20,000	2	2	5	7	11	15
25,000	2	2	5	7	12	17
30,000	2	3	5	8	13	18
35,000	2	3	5	8	13	18
40,000	2	3	6	9	14	19
50,000	2	3	6	9	14	20
60,000	2	3	6	10	15	22
70,000	3	4	7	11	17	23
80,000	3	4	7	12	17	23
90,000	3	4	7	12	17	24
100,000	3	4	8	13	18	25
150,000	3	5	9	14	21	27
200,000	4	6	9	16	23	32

# Let-Through Charts

## TRON® Class T Fast-Acting Fuses

JJN

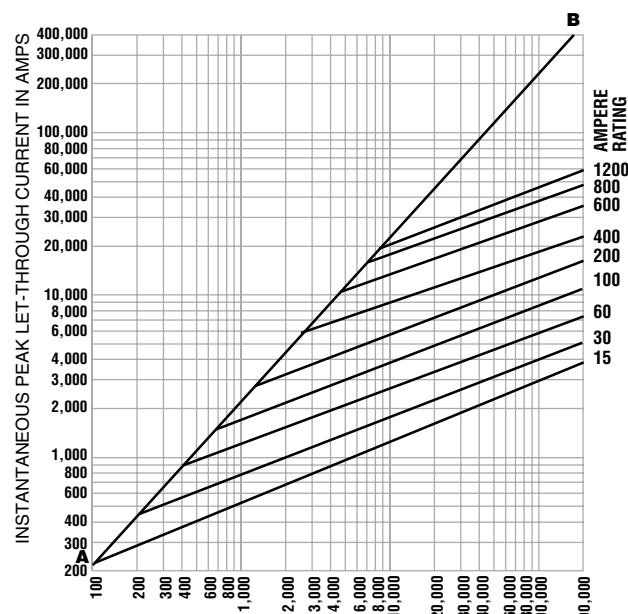

PROSPECTIVE SHORT-CIRCUIT CURRENT—SYMMETRICAL RMS AMPS

## JJN – RMS Let-Through Current (kA)

Prosp. Short C.C.	Fuse Size								
	15	30	60	100	200	400	600	800	1200
	I <sub>RMS</sub>	I <sub>RMS</sub>	I <sub>RMS</sub>	I <sub>RMS</sub>	I <sub>RMS</sub>	I <sub>RMS</sub>	I <sub>RMS</sub>	I <sub>RMS</sub>	I <sub>RMS</sub>
500	1	1	1	1	1	1	1	1	1
1,000	1	1	1	1	1	1	1	1	1
5,000	1	1	1	1	2	3	5	5	5
10,000	1	1	1	2	2	4	6	7	9
15,000	1	1	1	2	3	4	6	9	10
20,000	1	1	1	2	3	5	7	10	11
25,000	1	1	2	2	3	5	7	10	12
30,000	1	1	2	2	3	5	8	11	13
35,000	1	1	2	3	4	6	8	11	13
40,000	1	1	2	3	4	6	9	11	13
50,000	1	1	2	3	4	7	9	12	15
60,000	1	1	2	3	4	7	10	13	16
70,000	1	1	2	3	5	7	10	14	17
80,000	1	2	2	3	5	8	11	15	17
90,000	1	2	2	3	6	8	11	15	18
100,000	1	2	2	4	6	8	12	16	19
150,000	1	2	3	4	6	9	13	17	22
200,000	2	2	3	4	7	9	15	19	23

## TRON® Class T Fast-Acting Fuses

JJS

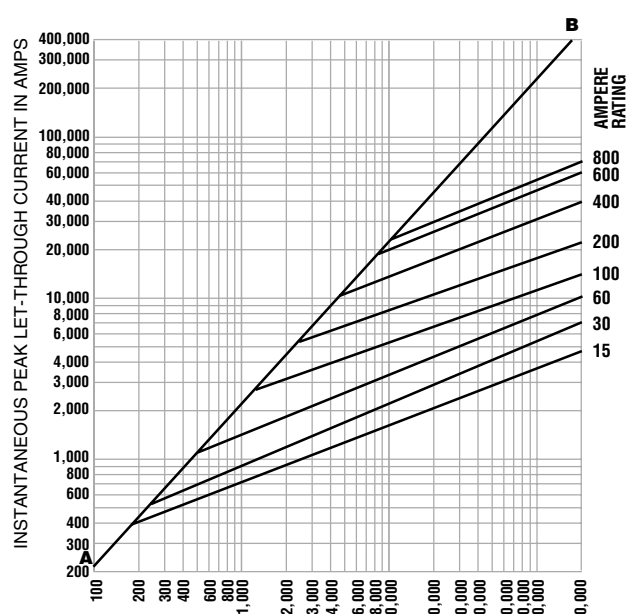

PROSPECTIVE SHORT-CIRCUIT CURRENT—SYMMETRICAL RMS AMPS

## JJS – RMS Let-Through Current (kA)

Prosp. Short C.C.	Fuse Size						
	15	30	60	100	200	400	800
	I <sub>RMS</sub>	I <sub>RMS</sub>	I <sub>RMS</sub>	I <sub>RMS</sub>	I <sub>RMS</sub>	I <sub>RMS</sub>	I <sub>RMS</sub>
500	1	1	1	1	1	1	1
1,000	1	1	1	1	1	1	1
5,000	1	1	1	2	3	4	5
10,000	1	1	1	2	3	6	8
15,000	1	1	2	3	4	7	10
20,000	1	1	2	3	4	7	10
25,000	1	1	2	3	5	7	11
30,000	1	1	2	3	5	8	12
35,000	1	1	2	3	5	9	13
40,000	1	2	2	4	5	9	13
50,000	1	2	2	4	6	10	14
60,000	1	2	3	4	6	10	16
70,000	1	2	3	4	7	11	17
80,000	1	2	3	4	7	11	17
90,000	1	2	3	4	7	12	18
100,000	2	2	3	5	7	12	19
150,000	2	3	4	6	8	14	22
200,000	2	3	4	6	9	16	24

# Conductor Protection

The increase in KVA capacity of power distribution systems has resulted in available short-circuit currents of extremely high magnitude. Fault induced, high conductor temperatures may seriously damage conductor insulation.

As a guide in preventing such serious damage, maximum allowable short-circuit temperatures, which begin to damage the insulation, have been established for various types of insulation. For example, 75°C thermoplastic insulation begins to be damaged at 150°C.

The Insulated Cable Engineers Association (ICEA) withstand chart, to the right, shows the currents, which, after flowing for the times indicated, will produce these maximum temperatures for each conductor size. The system available short-circuit current, conductor cross-sectional area, and the overcurrent protective device characteristics should be such that these maximum allowable short-circuit currents and times are not exceeded.

Using the formula shown on the ICEA protection chart will allow the engineer to calculate short-circuit current ratings of cable not shown on these pages. This can be used to find short-circuit current ratings where the clearing time is below 1 cycle. The table below the ICEA chart shows a summary of the information from the ICEA Chart/Formula.

The circuit shown in the figure below originates at a distribution panel with an available short-circuit current of 40,000 amperes RMS symmetrical. The 10 AWG THW copper conductor is protected by a Bussmann® LOW-PEAK® fuse sized per NEC® 240.4(D) (30A maximum for a 10 AWG conductor).

### Short-Circuit Protection of Wire and Cable

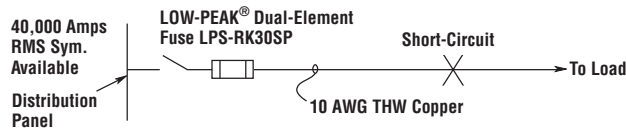

The ICEA table shows the 10 AWG conductor to have a short-circuit withstand rating of 6,020A for 1/2 cycle. By reviewing the let-through charts for the LPS-RK30SP, it can be seen that the fuse will reduce the 40,000A fault to a value of 2,000A and clear within 1/2 cycle. Thus, the 10 AWG conductor would be protected by the fuse.

Short-circuit protection of conductors is especially important for equipment grounding conductors since reduced sizing is permitted by Table 250.122. Similar concerns are present where circuit breakers with short-time delay are utilized, since this delays the short-circuit operation of circuit breakers. Motor circuits offer similar concerns (overload relays provide the overload protection, with branch-circuit protection being sized at several times the ampacity of the conductor).

### Short-Circuit Current Withstand Chart for Copper Cables with Thermoplastic Insulation Allowable Short-Circuit Currents for Insulated Copper Conductors\*

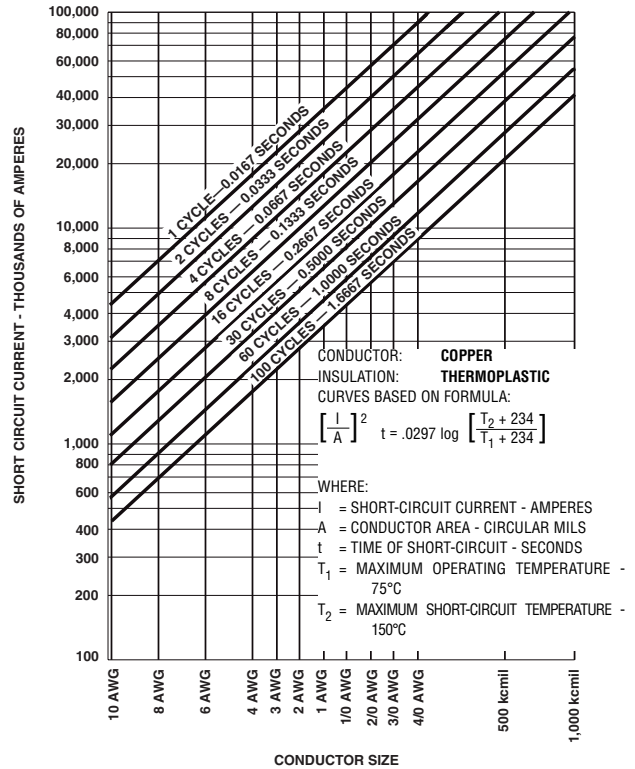

\*Copyright 1969 (reaffirmed March, 1992) by the Insulated Cable Engineers Association (ICEA). Permission has been given by ICEA to reprint this chart.

### Copper, 75° Thermoplastic Insulated Cable Damage Table (Based on 60 HZ)

Copper Wire Size 75°C Thermoplastic	Maximum Short-Circuit Withstand Current in Amperes					
	1/8 Cycles*	1/4 Cycles*	1/2 Cycles*	1 Cycle	2 Cycles	3 Cycles
18*	1850	1300	900	700	500	400
16*	3000	2100	1500	1100	700	600
14*	4,800	3,400	2,400	1,700	1,200	1,000
12*	7,600	5,400	3,800	2,700	1,900	1,550
10	12,000	8,500	6,020	4,300	3,000	2,450
8	19,200	13,500	9,600	6,800	4,800	3,900
6	30,400	21,500	16,200	10,800	7,600	6,200
4	48,400	34,200	24,200	17,100	12,100	9,900

\* Extrapolated data.

# Bus and Busway Protection

The short-circuit ratings of busways are established on the basis of minimum three-cycle duration tests, these ratings will not apply unless the protective device will remove the fault within three cycles or less.

If a busway has been listed or labeled for a maximum short-circuit current with a specific overcurrent device, it cannot be used where greater fault currents are available without violating the listing or labeling.

If a busway has been listed or labeled for a maximum short-circuit current without a specific overcurrent device (i.e., for three cycles), current-limiting fuses can be used to reduce the available short-circuit current to within the withstand rating of the busway.

Per NEMA Publication No. BU1-1999 - Busways may be used on circuits having available short-circuit currents greater than the three cycle rating of the busway rating when properly coordinated with current-limiting devices. Refer to the figures below for an analysis of the short-circuit current rating requirements for the 800 ampere plug-in bus depending upon the overcurrent device selected.

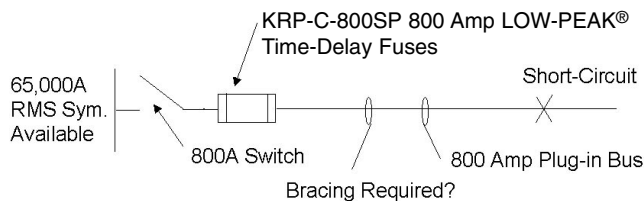

The 800 ampere plug-in bus could be subjected to 65,000 amperes at its line side; however, the KRP-C-800SP LOW-PEAK® time-delay fuses would limit this available current. When protected by KRP-C800SP LOW-PEAK® time-delay fuses, the 800 ampere bus need only be braced for 19,000 amperes RMS symmetrical. This would allow a standard 22,000 ampere RMS symmetrical (3-cycle) rated bus to be specified.

If a non-current-limiting type protective device, such as a standard 800A circuit breaker as shown below, were specified, the bracing requirements would have to be 65,000 amperes for three cycles.

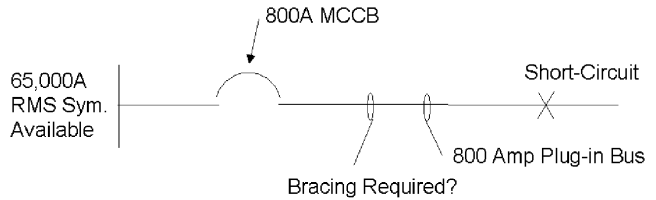

The table below shows the minimum bracing required for bus structures at 480V based upon the available short-circuit current.

This is based upon the let-through current of the fuse.

This can be used to avoid the need and added cost of higher bracing requirements for equipment.

**Minimum Bracing Required for Bus Structures at 480V. (Amperes RMS Symmetrical)**

Busway	Fuse	Available Short-Circuit Amperes RMS Sym.				
		25,000	50,000	75,000	100,000	200,000
100	100	3,400	4,200	4,800	5,200	6,500
225	225	6,000	7,000	8,000	9,000	12,000
400	400	9,200	11,000	13,000	14,000	17,000
600	600	12,000	15,000	17,000	19,000	24,000
601	601	11,000	14,500	17,000	18,000	24,000
800	800	14,200	17,500	20,000	23,000	29,000
1200	1200	16,000	22,500	26,000	28,000	39,000
1600	1600	22,500	28,500	33,000	36,000	46,000
2000	2000	25,000	32,000	37,000	40,000	52,000
3000	3000	25,000	43,000	50,000	58,000	73,000
4000	4000	25,000	48,000	58,000	68,000	94,000

\*Fuses are: 100-600 Ampere—LOW-PEAK® YELLOW Dual-Element Fuses—LPS-RK\_SP (Class RK1) or LPJ\_SP (Class J); 800-4000 Ampere—LOW-PEAK® YELLOW Time-Delay Fuses—KRP-C\_SP (Class L). (LOW-PEAK® YELLOW fuses are current-limiting fuses.)

# Motor Circuit Protection

The branch circuit protective device size cannot exceed the maximum rating per **NEC® 430.52** or the rating shown on equipment labels or controller manufacturers' tables. **NEC® 430.53** for group motor installations and **430.54** for multi-motor and combination-load equipment also require the rating of the branch circuit protective device to not exceed the rating marked on the equipment.

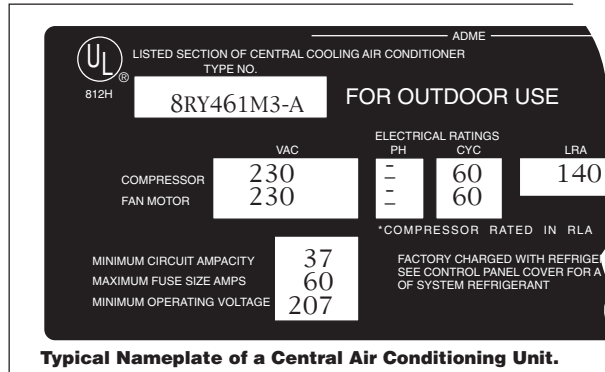

**Typical Nameplate of a Central Air Conditioning Unit.**

In no case can the manufacturer's specified rating be exceeded. This would constitute a violation of **NEC® 110.3(B)**. When the label, table, etc. is marked with a "Maximum Fuse Ampere Rating" rather than marked with a "Maximum Overcurrent Device" this then means only fuses can be used for the branch circuit protective device.

There are several independent organizations engaged in regular testing of motor controllers under short-circuit conditions. One of these, Underwriter's Laboratories, tests controllers rated one horsepower or less and 300 volts or less with 1000 amperes short-circuit current available to the controller test circuit. Controllers rated 50HP or less are tested with 5000 amperes available and controllers rated above 50HP to 200HP are tested with 10,000 amperes available. See the table below for these values (based upon UL 508).

Motor Controller HP Rating	Test Short-Circuit Current Available
1 HP or less and 300V or less	1,000A
50HP or less	5,000A
Greater than 50HP to 200HP	10,000A
201HP to 400HP	18,000A
401HP to 600HP	30,000A
601HP to 900HP	42,000A
901HP to 1600HP	85,000A

It should be noted that these are basic short-circuit requirements. Even at these minimum levels, controller components are allowed to be permanently damaged, or destroyed, requiring replacement before the motor circuit can be safely reenergized. Higher combination ratings are attainable, but even more significant, permanent damage is allowed.

Compliance with the UL 508 standard allows deformation of the enclosure, but the door must not be blown open and it must be possible to open the door after the test. In addition, the enclosure must not become energized and discharge of parts from the enclosure is not permitted. In the standard short-circuit tests, the contacts must not disintegrate, but welding of the contacts is considered acceptable. Tests allow the overload relay to be damaged with burnout of the current element completely acceptable. For short-circuit ratings in excess of the standard levels listed in UL 508, the damage allowed is even more severe. Welding or complete disintegration of contacts is acceptable and complete burnout of the overload relay is allowed. Therefore, a user cannot be certain that the motor starter will not be damaged just because it has been UL Listed for use with a specific branch circuit protective device.

### Type 1 vs. Type 2 Protection

Coordinated protection of the branch circuit protective device and the motor starter is necessary to insure that there will be no permanent damage or danger to either the starter or the surrounding equipment. There is an "Outline of Investigation", (UL508E) and an IEC (International Electrotechnical Commission) Standard, IEC Publication 60947, "Low Voltage Switchgear and Control, Part 4-1: Contactors and Motor Starters", that offer guidance in evaluating the level of damage likely to occur during a short-circuit with various branch-circuit protective devices. These standards define two levels of protection (coordination) for the motor starter:

**Type 1.** Considerable damage to the contactor and overload relay is acceptable. Replacement of components or a completely new starter may be needed. There must be no discharge of parts beyond the enclosure. In addition, the enclosure must not become energized and discharge of parts from the enclosure is not permitted. See figure to right.

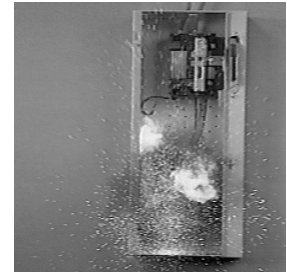

**Type 2.** No damage is allowed to either the contactor or overload relay. Light contact welding is allowed, but must be easily separable. Manufacturers have verified most of their NEMA and IEC motor controllers to meet the Type 2 requirements as outlined in UL508E or IEC 60947-4-1. Only extremely current-limiting devices have been able to provide the current-limitation necessary to provide verified Type 2 protection. In most cases, Class J, Class RK1, or Class CC fuses are required to provide Type 2 protection. To achieve Type 2 protection, use motor starters that are investigated to UL508E Type 2 with the type and size of fuse recommended.

Type 2 "no damage" protection tables by controller manufacturers' part numbers with verified fuse protection located on [www.bussmann.com](http://www.bussmann.com)



# Series Ratings

Most electrical distribution systems are fully rated as required by NEC® 110.9. A fully rated system is a system where every overcurrent protective device has an interrupting rating equal to or greater than the available fault. Fully rated systems are typically preferred and recommended, but electrical distribution systems are permitted to incorporate series ratings, provided all the requirements of NEC® 240.86 and 110.22 are met. However, the actual application of series ratings is typically limited.

Series rating is a combination of circuit breakers, or fuses and circuit breakers, that can be applied at available short-circuit levels above the interrupting rating of the load side circuit breakers, but not above that of the main or line-side device. Series ratings can consist of fuses protecting circuit breakers, or circuit breakers protecting circuit breakers.

**Series Rating Circuit Breakers.** In the example below, the 20A, 10,000A interrupting rating circuit breaker has been tested, for a series combination interrupting rating of 65,000A when protected by the upstream 200A, 65,000A interrupting rating circuit breaker. The circuit breaker types for this series combination rating would have to be verified by the evidence of the panelboard or switchboard marking as required by NEC® 240.86(A).

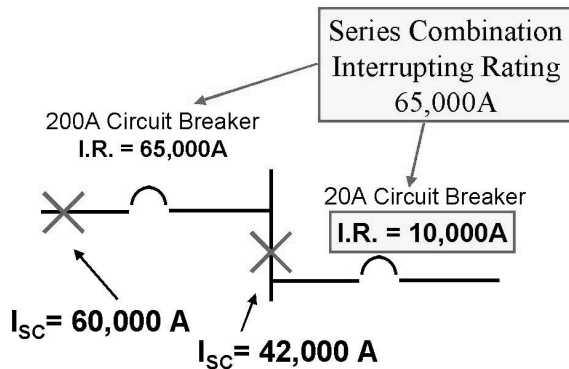

**Series Rating Fuse and Circuit Breakers.** In the example below, a 20A, 10,000A interrupting rating circuit breaker has been tested, for a series combination interrupting rating of 200,000A when protected by the upstream Class J fuse. The fuse and circuit breaker types for this series combination rating would have to be verified by the evidence of the panelboard or switchboard marking as required by NEC® 240.86(A).

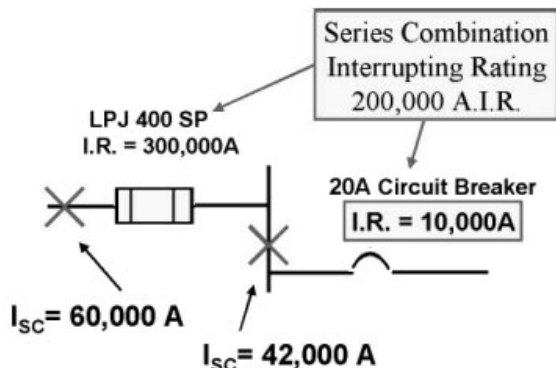

While there is only one advantage to utilizing a series combination rating...lower installed cost, several special requirements or limitations exist and are discussed below.

**Special Requirements For Applying a Series Combination Rating**

Special requirements and limitations must be considered for the application of a series combination rating, which include:

- Motor contribution limitation
- Manufacturer labeling requirements
- Field labeling requirements
- Lack of coordination limitation
- Proper selection of series combination ratings

**Motor Contribution Limitation**

The first critical requirement limits the application of a series combination rating where motors are connected between the line-side (protecting) device and the load-side (protected) circuit breaker. NEC® 240.86(B) requires that series ratings shall not be used where the sum of motor full load currents exceeds 1% of the interrupting rating of the load-side (protected) circuit breaker.

The example to the right shows a violation of 240.86(B) due to motor contributions. Since the motor load exceeds 1% of the load-side circuit breaker (10,000 X 0.01 = 100A), this series rated combination cannot be applied.

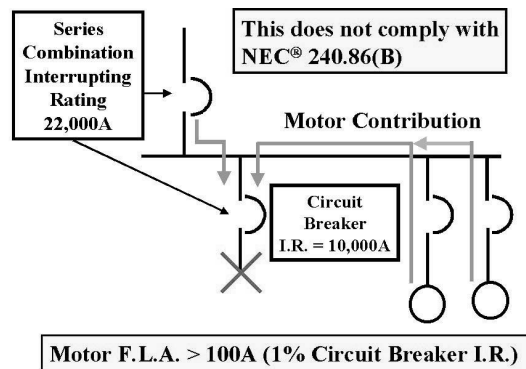

# Series Ratings

## Manufacturer Labeling Requirement

NEC® 240.86(A) requires that, when series ratings are used, the switchboards, panelboards, and loadcenters must be marked with the series combination interrupting rating for specific devices utilized in the equipment.

Because there is often not enough room in the equipment to show all of the legitimate series combination ratings, UL 67 (Panelboards) allows for a bulletin to be referenced and supplied with the panelboard (see the example shown to the right). These bulletins or manuals typically provide all of the acceptable series combination ratings. The difficulty is that these bulletins often get misplaced. Because of this, some manufacturers add additional labels with information on how to get replacement manuals (see the example shown below).



## Field Labeling Requirement

NEC® 110.22 requires that where overcurrent protective devices are applied with a series combination rating in accordance with the manufacturer's equipment marking, an additional label must be added in the field. This label must indicate the equipment has been applied with a series combination rating and identify specific replacement overcurrent devices required to be utilized.

The figure below shows an example of the field labeling required by NEC® 110.22. The equipment for both devices of the series combination rating is marked as shown in the figure to assure the series combination rating is maintained during the replacement of devices.

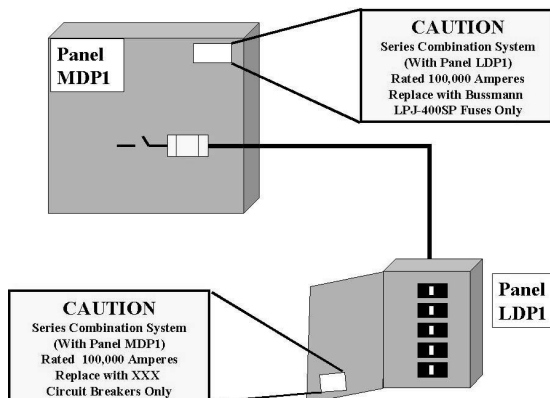

## Lack of Coordination Limitation

One of the biggest disadvantages with the application of series combination ratings is that, by definition, the line side device must open in order to protect the load side circuit breaker. With the line side device opening, all other loads will experience an unnecessary power loss.

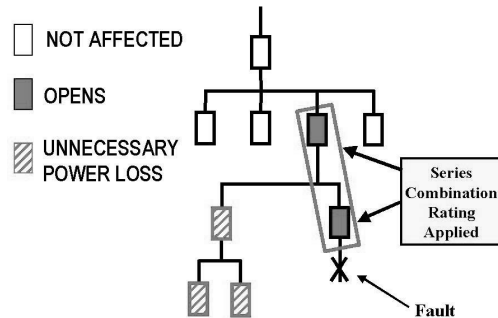

The example above shows a lack of selective coordination inherent to series combination rating applications. This lack of coordination can cause unnecessary power loss to unfaulted loads and adversely affect system continuity.

Because of the inherent lack of coordination, the application of series combination ratings are best avoided in service entrance switchboards (main and feeders), distribution panels, as well as any critical or emergency distribution panels or any other application where coordination is required.

## Proper Selection of Series Combination Ratings

If the application utilizes a series combination rating, refer to the manufacturer's literature for panelboards, load centers, and switchboards which have been tested, listed and marked with the appropriate series combination ratings. During this process, one will most likely notice that series combination ratings with upstream devices above 400A are very limited. Because of this, series rating in switchboards or higher ampacity distribution panelboards (above 400A) may not be available. For this reason, as well as continuity of service, most series rated applications are best suited for lighting panels (400A or less).

For a table containing fuse/circuit breaker series combination ratings, see page 35.

# Selective Coordination

Selective coordination is often referred to simply as coordination. Coordination is defined in NEC® 240.2 as: “The proper localization of a fault condition to restrict outages to the equipment affected, accomplished by the choice of selective fault-protective devices.”

It is important to note that the type of overcurrent protective device selected often determines if a system is selectively coordinated.

The figure below shows the difference between a system without selective coordination and a system with selective coordination. The figure on the left shows a system without selective coordination. In this system, unnecessary power loss to unaffected loads can occur, since the device nearest the fault cannot clear the fault before devices upstream open. The system on the right shows a selectively coordinated system. Here, the fault is cleared by the overcurrent device nearest the fault before any other upstream devices open, and unnecessary power loss to unaffected loads is avoided.

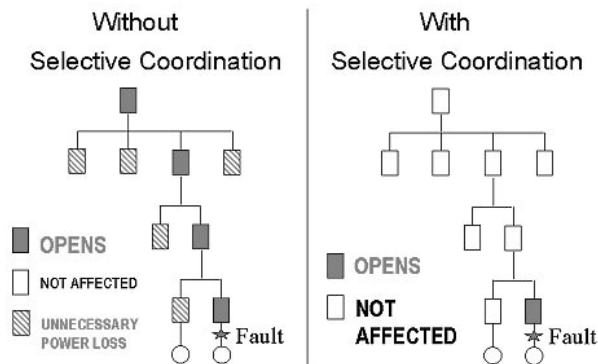

## Selective Coordination - NEC®

The NEC® discusses selective coordination in 240.12 and states: “Where an orderly shutdown is required to minimize the hazard(s) to personnel and equipment, a system of coordination based on the following two conditions shall be permitted:

- 1) Coordinated short-circuit protection
- 2) Overload indication based on monitoring system or devices.

FPN: The monitoring system may cause the condition to go to alarm, allowing corrective action or an orderly shutdown, thereby minimizing personnel hazards and equipment damage.”

In addition, coordination is specifically required in health care facilities (per NEC® 517.17) and multiple elevator circuits (per NEC® 620.62). Good design practice considers continuity of service, cost of downtime, lost worker productivity, and safety of building occupants.

## Methods of Performing a Coordination Study

Two methods are most often used to perform a coordination study:

1. Overlays of time-current curves, which utilize a light table and manufacturers' published data.
2. Computer programs that utilize a PC and allow the designer to select time-current curves published by manufacturers.

Regardless of which method is used, a thorough understanding of time-current characteristic curves of overcurrent protective devices is essential to provide a selectively coordinated system. For fuse systems, verification of selective coordination is quick and easy, merely adhere to fuse ampere rating ratios as indicated by the manufacturer.

It should be noted that the study of time-current curves indicates performance during overload and low-level fault conditions. The performance of overcurrent devices that operate under medium to high level fault conditions are not reflected on standard time-current curves. Other engineering methods must be utilized.

# Selective Coordination – Circuit Breakers

The curve to the right shows a 90 ampere circuit breaker and an upstream 400 ampere circuit breaker with an instantaneous trip setting of 5 (5 times 400A = 2000A).

The minimum instantaneous unlatching current for the 400A circuit breaker could be as low as 2000A times .75 = 1500A (± 25% band). If a fault above 1500 amperes occurs on the load side of the 90 ampere breaker, both breakers could open. The 90 ampere breaker generally unlatches before the 400 ampere breaker. However, before the 90 ampere breaker can clear the fault current, the 400 ampere breaker could have unlatched and started to open as well. The example below illustrates this point.

Assume a 4000 ampere short-circuit exists on the load side of the 90 ampere circuit breaker. The sequence of events would be as follows:

1. The 90 ampere breaker unlatches (Point A).
2. The 400 ampere breaker unlatches (Point B). Once a breaker unlatches, it will open. At the unlatching point, the process is irreversible.
3. At Point C, the 90 ampere breaker will have completely interrupted the fault current.
4. At Point D, the 400 ampere breaker also will have completely opened.

Consequently, this is a **non-selective** system, causing a blackout to the other loads protected by the 400A breaker.

This is typical for molded case circuit breakers due to the instantaneous trip and wide band of operation on medium to high fault conditions. In addition, this can affect other upstream molded case circuit breakers depending upon the size and the instantaneous setting of the circuit breakers upstream and the magnitude of the fault current.

### Circuit Breakers with Short-Time-Delay and Instantaneous Override

Some electronic trip molded case circuit breakers and most insulated case circuit breakers (ICCB) offer short-time delay (STD). This allows the circuit breaker the ability to delay tripping for a period of time, typically 6 to 30 cycles. However, with electronic trip molded case circuit breakers and insulated case circuit breakers, a built-in instantaneous override mechanism is present. This is called the instantaneous override function, and will override the STD for medium to high level faults. The instantaneous override setting for these devices is typically 8 to 12 times the rating of the circuit breaker and will “kick in” for faults equal to or greater than the override setting. Because of this instantaneous override, non-selective tripping can exist, similar to molded case circuit breakers and insulated case circuit breakers without short-time delay. Thus, while short-time delay in molded case and insulated case circuit breakers can improve coordination in the overload and low level fault regions, it may not be able to assure coordination for medium and high level fault conditions.

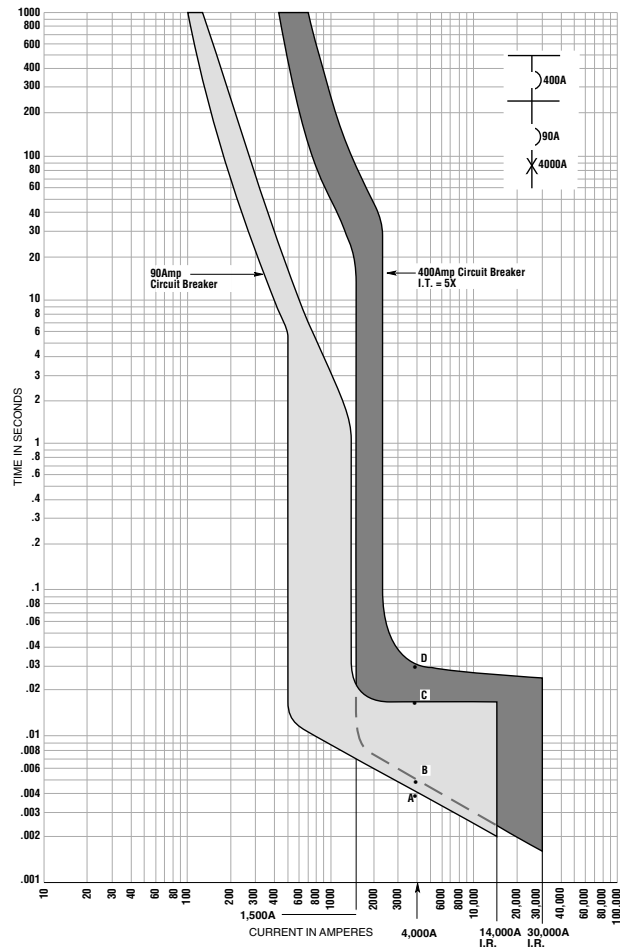

### Low Voltage Power Circuit Breakers (LVPCB) with Short-Time Delay

Short-time-delay, with settings from 6 to 30 cycles, is also available on low voltage power circuit breakers. However, with low voltage power circuit breakers an instantaneous override is not required. Thus, low voltage power circuit breakers with short-time delay can hold into faults for up to 30 cycles. This allows the downstream device to open the fault before the upstream low voltage power circuit breaker opens. However, if the fault is between the downstream device and the low voltage power circuit breaker, the electrical equipment can be subjected to unnecessarily high mechanical and thermal stress.

# Selective Coordination - Fuses

The figure to the right illustrates the time-current characteristic curves for two sizes of time-delay, dual-element fuses in series, as depicted in the one-line diagram. The horizontal axis of the graph represents the RMS symmetrical current in amperes. The vertical axis represents the time, in seconds.

**For example:** Assume an available fault current level of 1000 amperes RMS symmetrical on the load side of the 100 ampere fuse. To determine the time it would take this fault current to open the two fuses, first find 1000 amperes on the horizontal axis (Point A), follow the dotted line vertically to the intersection of the total clear curve of the 100 ampere time-delay dual-element fuse (Point B) and the minimum melt curve of the 400 ampere time-delay dual-element fuse (Point C). Then, horizontally from both intersection points, follow the dotted lines to Points D and E. At 1.75 seconds, Point D represents the maximum time the 100 ampere time-delay dual-element fuse will take to open the 1000 ampere fault. At 88 seconds, Point E represents the minimum time at which the 400 ampere time-delay dual-element fuse could open this available fault current. Thus, coordination is assured for this level of current.

The two fuse curves can be examined by the same procedure at various current levels along the horizontal axis (for example, see Points F and G at the 2000 ampere fault level). It can be determined that the two fuses are coordinated, since the 100 ampere time-delay dual-element fuse will open before the 400 ampere time-delay dual-element fuse can melt. Notice above approximately 4,000A, coordination can not be determined by the time-current curves.

Fuse coordination for the overload region and low fault currents can be shown using the time-current curves. For medium and high fault currents, the time-current curve can not be used, but as long as the downstream fuse clears the fault before the upstream fuse begins to open, coordination is assured.

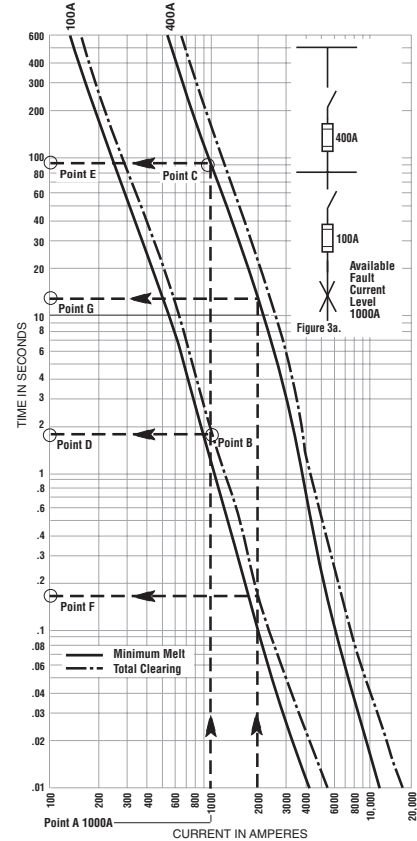

In order to verify the coordination ability of fuses, fuse manufacturers have developed an engineering tool to aid in the proper selection of fuses for selective coordination. The Selectivity Ratio Guide (SRG) is shown to the right and is based upon Bussmann® fuses. Note that for Bussmann® LOW-PEAK® Fuses, a 2:1 ratio is all that is needed to obtain selective coordination. For coordination ratios for other manufacturers, manufacturer's literature must be consulted.

**\* Selectivity Ratio Guide (Line-Side to Load-Side) for Blackout Prevention**

Circuit		Load-Side Fuse											
Current Rating		601-6000A	601-4000A	0-600A			601-6000A	0-600A	0-1200A	0-600A	0-60A		
Type		Time-Delay	Time-Delay	Dual-Element Time-Delay			Fast-Acting	Fast-Acting			Time-Delay		
Trade Name		LOW-PEAK® YELLOW	LIMITRON	LOW-PEAK® YELLOW			FUSETRON®	LIMITRON	LIMITRON	T-TRON®	LIMITRON	SC	
Class		(L)	(L)	(RK1)	(J)	(RK5)	(L)	(RK1)	(T)	(J)	(G)		
Buss® Symbol		KRP-C_SP	KLU	LPN-RKSP	LPJ-SP	FRN-R	KTU	KTN-R	JJN	JKS	SC		
Symbol		KRP-C_SP	KLU	LPN-RKSP	LPJ-SP	FRN-R	KTU	KTN-R	JJN	JKS	SC		
Line-Side Fuse	601 to 6000A Time-Delay	LOW-PEAK® YELLOW (L)	KRP-C_SP	2:1	2.5:1	2:1	2:1	4:1	2:1	2:1	2:1	2:1	N/A
	601 to 4000A Time-Delay (L)	LIMITRON® (L)	KLU	2:1	2:1	2:1	2:1	4:1	2:1	2:1	2:1	2:1	N/A
	0 to 6000A Dual-Element (RK1)	LOW-PEAK® YELLOW (L)	LPN-RKSP	-	-	2:1	2:1	8:1	-	3:1	3:1	3:1	4:1
	6000A Dual-Element (J)	LPS-RKSP	LPJ-SP	-	-	2:1	2:1	8:1	-	3:1	3:1	3:1	4:1
	601 to 6000A Dual-Element (RK5)	FUSETRON® (RK5)	FRN-R	-	-	1.5:1	1.5:1	2:1	-	1.5:1	1.5:1	1.5:1	1.5:1
	601 to 6000A Dual-Element (L)	LIMITRON (L)	KTU	2:1	2.5:1	2:1	2:1	6:1	2:1	2:1	2:1	2:1	N/A
	0 to 6000A Fast-Acting (RK1)	LIMITRON (RK1)	KTN-R	-	-	3:1	3:1	8:1	-	3:1	3:1	3:1	4:1
	0 to 1200A Fast-Acting (T)	T-TRON® (T)	JJN	-	-	3:1	3:1	8:1	-	3:1	3:1	3:1	4:1
	0 to 6000A Fast-Acting (J)	LIMITRON (J)	JKS	-	-	2:1	2:1	8:1	-	3:1	3:1	3:1	4:1
	0 to 60A Time-Delay (G)	SC (G)	SC	-	-	3:1	3:1	4:1	-	2:1	2:1	2:1	2:1

\* **Note:** At some values of fault current, specified ratios may be lowered to permit closer fuse sizing. Plot fuse curves or consult with Bussmann®. General Notes: Ratios given in this Table apply only to Buss® fuses. When fuses are within the same case size, consult Bussmann®.

# Maintenance and Testing Considerations

When designing electrical distribution systems, required maintenance and testing of the overcurrent protective devices is a very important consideration. The electrical system reliability, component and circuit protection, and overall safety are directly related to the reliability and performance of the overcurrent protective device and can depend upon whether the required testing and maintenance are performed as prescribed for the overcurrent protective device utilized. The required maintenance and testing of the system can depend upon the type of overcurrent protective device selected.

## Circuit Breakers

Many engineers and owners view molded case circuit breaker systems as “easy”...just install it, reset the devices if needed and walk away. However, periodic testing and maintenance of circuit breakers is extremely important to the system reliability and protection.

NFPA 70B (1998) - Recommended Practice for Electrical Equipment Maintenance indicates that testing and maintenance of molded case circuit breakers should be completed every 6 months to 3 years, depending upon the conditions of use. This includes typical maintenance such as tightening of connections, checking for signs of overheating, and checking for any structural defects or cracks. Manual operation of the circuit breaker is typically recommended to be completed once per year. Testing of molded case circuit breakers to assure proper overcurrent protection and operation is also recommended during this period. This includes removing the circuit breaker and verifying the protection and operation for overloads (typically 300%) with the manufacturer's overcurrent trip data. Additional molded case circuit breaker testing of insulation resistance, individual pole resistance, rated hold-in, and instantaneous operation are recommended by NEMA and may require special testing equipment.

It is important to realize that if a deficiency is discovered during testing and maintenance, the only solution is to replace a molded case circuit breaker because adjustments or repairs cannot be made to this type of device. In addition, replacement is typically recommended after the molded case circuit breaker has interrupted a short-circuit current near its marked interrupted rating. This process results in additional expenses and may involve delays in finding a replacement device.

Per NFPA 70B, testing and maintenance of low-voltage power circuit breakers is even more expansive and can be required after tripping on an overcurrent condition. It is important to realize that the maintenance and testing of these devices can only be completed by a qualified person. Often special testing companies are used for this purpose or the device must be sent back to the manufacturer, requiring spare devices during this period.

The question is, how often is this completed? In commercial installations, the answer is probably never. This lack of maintenance and testing can adversely affect the reliability and protection capabilities during overcurrent conditions in the electrical distribution system.

## Fuses

NFPA 70B recommends checking fuse continuity during scheduled maintenance, but testing to assure proper operation and protection against overcurrent conditions is not required. Fusible switches and fuse blocks require maintenance, such as tightening of connections and checking for signs of overheating as recommended per NFPA 70B.

## Resetting Overcurrent Protective Devices.

As mentioned previously, circuit breakers are sometimes selected over fuses because circuit breakers can be reset where fuses have to be replaced. The most time consuming activity that results from the operation of the overcurrent protective device is typically investigating the cause of the overcurrent condition. A known overload condition is the only situation that permits the immediate resetting or replacement of overcurrent protective devices per OSHA. If the cause for the operation of an overcurrent protective device is not known, the cause *must* be investigated. Thus, having a device that can be easily reset, such as a circuit breaker, possibly into a fault condition, could be a safety hazard and a violation of OSHA regulations. Because a fuse requires replacement by a qualified person, it is less likely to violate OSHA. Also, when an opened fuse is replaced with a new fuse in the circuit, the circuit is protected by a new factory calibrated device.

Generally, overload conditions occur on branch-circuit devices. Typically this is on lighting and appliance circuits feed from circuit breaker panelboards, where resetting of circuit breakers may be possible. Motor circuits also are subject to overload considerations. However, typically the device that operates is the overload relay, which can be easily reset after an overload situation. The motor branch-circuit device (fuse or circuit breaker) operates, as indicated in NEC® 430.52, for protection of short-circuits and ground-fault conditions. Thus, if this device opens, it should not be reset or replaced without investigating the circuit since it most likely was a short-circuit condition. Overcurrent conditions in feeders and mains are typically the result of short-circuits and are infrequent. Because they are most likely short-circuits, the circuit should be investigated first before resetting or replacing as well. Also, if a feeder or main is protected by a circuit breaker that has opened, the circuit breaker should be examined and tested to be sure it is suitable to be placed back in service.

# Grounding & Bonding of Service Equipment

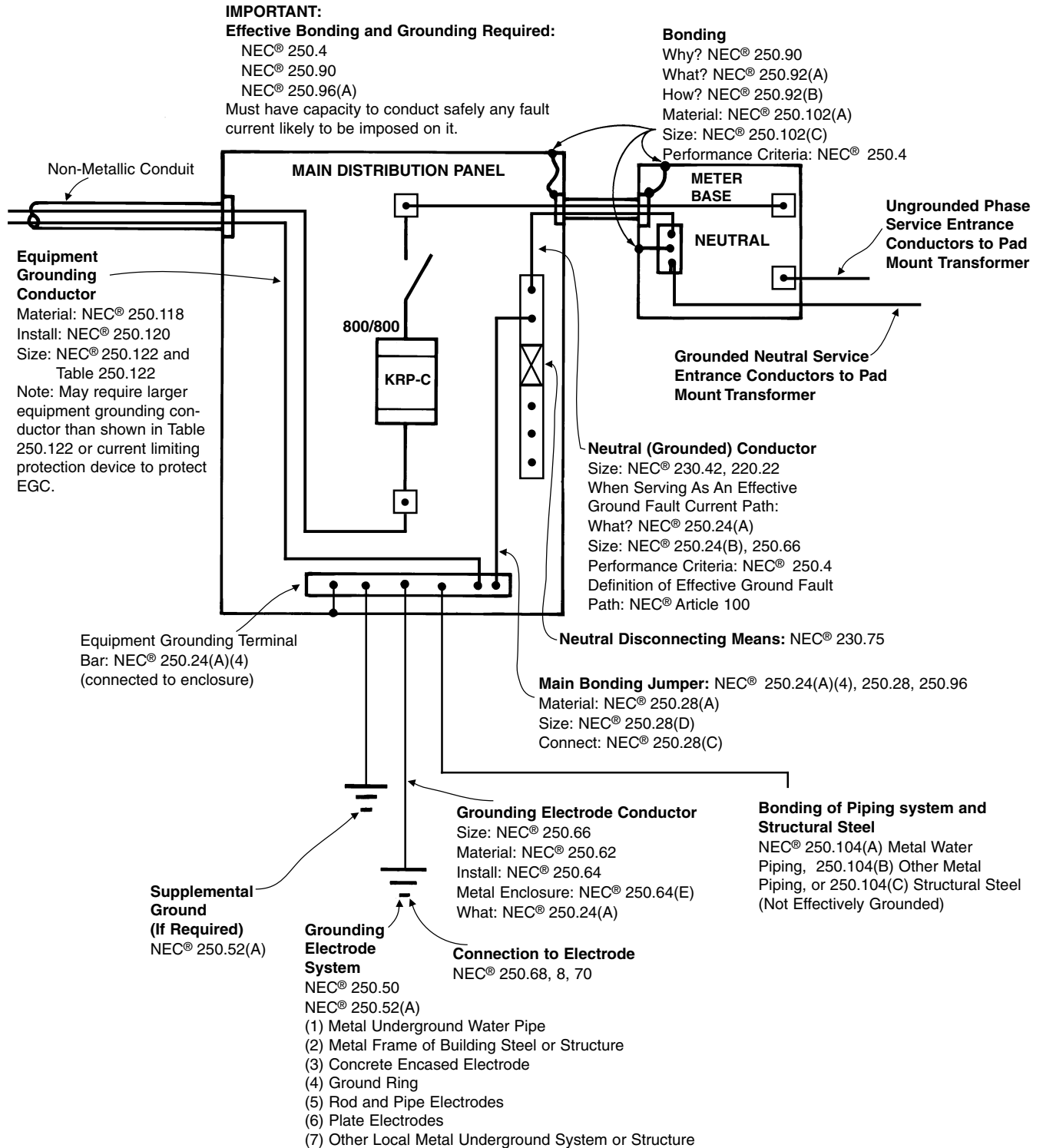

# Data "Log In"—Letter



## **CITY OF ANYWHERE, USA DEPARTMENT OF ELECTRICAL INSPECTION**

DATE \_\_\_\_\_

TO: ELECTRICAL CONTRACTORS, ENGINEERS, ARCHITECTS.  
RE: ELECTRIC SERVICE PERMIT APPLICATION.

COMPLIANCE WITH THE NATIONAL ELECTRICAL CODE® (NEC):  
Article 110, Article 210, Article 215, Article 230, Article 240,  
Article 250, Article 310, Article 404, Article 408, Article 430,  
Article 450, and Article 620.

The City of \_\_\_\_\_, Department of Electrical  
Inspection is required to enforce the 2002 National Electrical Code®.  
To ensure compliance, attention will be given to the SHORT-CIRCUIT  
RATINGS of the equipment and overcurrent devices to be installed.

To accomplish this with minimum effort and time, the attached  
form(s) are required to be completed by the electrical contractor,  
then submitted to the Electrical Inspection Department PRIOR to  
actual installation. Include a one-line riser diagram showing conduc-  
tor sizes, conduit sizes, distances, and fault currents at all panels,  
motor control centers, and main service equipment.

This data will be reviewed for compliance and conformance to the  
above Code sections and will be kept on file for future reference.

Sincerely,

Chief Electrical Inspector



# Data "Log In"—Form

## DEPARTMENT OF ELECTRICAL INSPECTION

CITY OF \_\_\_\_\_

Date \_\_\_\_\_

Permit \_\_\_\_\_

\_\_\_\_\_  
**Electrical Contractor**

\_\_\_\_\_  
**Street Address**

\_\_\_\_\_  
**City**

\_\_\_\_\_  
**State**

\_\_\_\_\_  
**Zip**

The following information is requested to determine that the electrical equipment to be installed at:

\_\_\_\_\_  
**Name of occupant or owner**

\_\_\_\_\_  
\_\_\_\_\_  
\_\_\_\_\_

is in compliance with the National Electrical Code® as it relates to available short-circuit currents and interrupting ratings, component protection and selective coordination. See NEC®: 110.3(B), 110.9, 110.10, Article 210, Article 215, Article 230, Article 240, Article 250, Article 310, Article 404, Article 408, Article 430, Article 450 and 620.62. This form is to be completed and returned to the Department of Electrical Inspection for approval prior to installation. THE FOLLOWING INFORMATION IS TO BE SUPPLIED BY THE ELECTRICAL CONTRACTOR OR OTHER RESPONSIBLE PARTY:

TRANSFORMER KVA \_\_\_\_\_ IMPEDANCE \_\_\_\_\_ % SECONDARY VOLTAGE \_\_\_\_\_

PHASE \_\_\_\_\_ 3 OR 4 WIRE \_\_\_\_\_ LENGTH OF SERVICE CONDUCTORS \_\_\_\_\_

SIZE & NUMBER OF SERVICE CONDUCTORS PER PHASE \_\_\_\_\_

TYPE OF CONDUCTORS: COPPER  ALUMINUM  CONDUIT SIZE \_\_\_\_\_ STEEL  NON-MAGNETIC

TYPE, SIZE, AND INTERRUPTING RATING OF OVERCURRENT DEVICES IN SERVICE DISCONNECT (MAIN DISTRIBUTION PANEL) \_\_\_\_\_  
\_\_\_\_\_

SIZE OF GROUNDING ELECTRODE CONDUCTOR \_\_\_\_\_ BRACING OF SERVICE EQUIPMENT \_\_\_\_\_

# Data "Log In"—Form

I T E M	Location Of Short-Circuit Current	Short- Circuit Current	Overcurrent Device		Equipment Rating (If Required)	
			Ampere Rating	Interrupting Rating (IR)	Short-Circuit Current Rating (SCCR)	If SCCR is below short-circuit current, must prove protection
1	AT TRANSFORMER SECONDARY TERMINALS					
2	AT LINE SIDE OF MAIN DISTRIBUTION PANEL					
3	AT PANEL LPA					
4	AT PANEL LPC					
5	AT PANEL LPB					
6	AT DISCONNECT AC-1					
7	AT DISCONNECT AC-2					
8	AT EMERGENCY PANEL					
9	AT FLUOR. FIXTURE					
10	AT COMBINATION MOTOR CONT.					
11						
12						

Use back of form or attach separate sheet for data on additional panels.

Use back of form or attach separate sheet to show one-line diagram of service, feeders, and all related panels.

Attach series rated charts for protection of circuit breakers and let-through charts for protection of passive components.

All current values in RMS unless otherwise noted.

The undersigned accepts full responsibility for the values given herein.

SIGNED \_\_\_\_\_ DATE \_\_\_\_\_

PHONE WHERE YOU CAN BE REACHED \_\_\_\_\_

# Inspection Form: Series Rated Combination

ISSUED BY: \_\_\_\_\_

This form provides documentation to assure compliance with the following National Electrical Code®, NFPA 70, sections on the use of Series Rated Combinations: **110.9, 110.22 & 240.86**

JOB # \_\_\_\_\_

NAME: \_\_\_\_\_

LOCATION: \_\_\_\_\_

CONTRACTOR: \_\_\_\_\_

## ESSENTIAL INFORMATION:

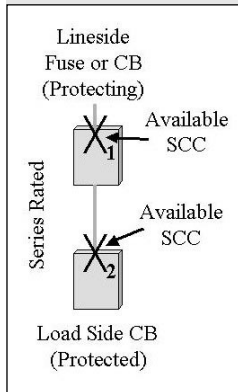

**Line Side Panel Designation (If applicable)** \_\_\_\_\_

Line Side Overcurrent Protective Device Part Number \_\_\_\_\_

Line Side Overcurrent Protective Device Interrupting Rating \_\_\_\_\_

**X<sub>1</sub>** Available Short Circuit Current at Line side OCP Device \_\_\_\_\_

**Load Side Panel Designation** \_\_\_\_\_

Load Side Circuit Breaker Part Number \_\_\_\_\_

Load Side Circuit Breaker Individual Interrupting Rating \_\_\_\_\_

Series Combination Interrupting Rating \_\_\_\_\_

**X<sub>2</sub>** Available Short Circuit Current at Load side Circuit Breaker \_\_\_\_\_

## Compliance Checklist

*(For further information see discussion on reverse side for each item)*

### 1. Short-Circuit Currents

Is the interrupting rating of the line side fuse or circuit breaker greater than the available short-circuit current (**X<sub>1</sub>**) at its lineside (110.9)  YES  NO

Is the series combination interrupting rating greater than the available short-circuit current (**X<sub>2</sub>**) at the load side circuit breaker (permitted per 240.86)?  YES  NO

### 2. Manufacturer's Label

Are both devices in use for the series rated combination marked on the end use equipment in which the load side circuit breaker is installed (or contained in a booklet affixed to the equipment) as required in 240.86(A)?  YES  NO

### 3. Field Installed Label

Are field labels, as required by 110.22, that indicate "CAUTION – Series Rated Combination", along with the required replacement parts, panel designations, and series combination interrupting rating, installed on all end use equipment that contain the series combination rating devices?  YES  NO

### 4. Motor Contribution

If motors are connected between the series rated devices, is the combined full load current from these motors less than 1% of the downstream circuit breakers' interrupting rating (individual or stand alone interrupting rating) per 240.86(B)?  YES  NO

### 5. Selective Coordination

Is this series rated combination being installed in something other than a health care facility (see NEC® 517.17)?  YES  NO

Elevator circuits only: Is this series rated combination being installed on an elevator circuit with only one elevator in the building (see NEC® 620.62)?  YES  NO

**AN ANSWER OF "NO" TO ANY OF THESE QUESTIONS MAY INDICATE A LACK OF COMPLIANCE. LACK OF SUBMITTAL IS CONSIDERED AS EVIDENCE OF LACK OF COMPLIANCE.**

# Cutler-Hammer Series Ratings

Switchboards: PRL-C / PRL-i

Panelboards: PRL 5P, PRL 4, PRL 3A & Pow-R-Command Panelboards (See Notes on Page 37)

Max System Voltage	SCIR*	Line Side Fuse	Max Fuse Current Rating	Load Side			
				Circuit Breaker	Amps	Poles	
120/240	100kA	LPN-RK	200	GB, GHB	ALL	1,2	
		JJN, LPJ	400	BA, BAB, HQP, QBHW, QPHW	ALL	1,2	
	200kA	LPN-RK	100	BA, BAB, HQP, QBHW, QPHW, GB, GHB	ALL	1,2	
		JJN, LPJ	200	BA, BAB, HQP, QBHW, QPHW	ALL	1,2	
		JJN, LPJ	400	GB, GHB	ALL	1,2	
	240	100kA	LPN-RK	200	GHB	ALL	1,2,3
				GB, CA	ALL	2,3	
JJN, LPJ			400	BAB_H, QBHW_H, HQP_H, QPHW_H	ALL	2,3	
JJN			600	CA, CAH, HCA	ALL	2,3	
KRP-C			6000	EHD, FD	ALL	1,2,3	
200kA		KRP-C	6000	FDB, ED, JDB, JD, DK, KDB, KD	ALL	2,3	
		LPN-RK	100	GHB	ALL	1,2,3	
				BAB_H, QBHW_H, HQP_H, QPHW_H, CAH, HCA, GB	ALL	2,3	
		LPN-RK	200	GB, GHB	ALL	2,3	
		JJN, LPJ	200	BAB_H, HQP_H, QBHW_H, QPHW_H, CA, CAH, HCA	ALL	2,3	
		JJN, LPJ	400	GHB	ALL	1,2,3	
				GB	ALL	2,3	
480/277	65kA	JJS, LPJ	200	GHBS	ALL	1,2	
	100kA	JJS, LPJ	100	GHBS	ALL	1,2	
		LPS-RK	200	GHB	ALL	1,2,3	
		LPJ	600	EHD, FD, HFD, FDC	ALL	2,3	
		JJS	600	GHB, EHD, FD, HFD, FDC, JD, HJD, JDC	ALL	2,3	
	200kA	LPS-RK	100	GHB	ALL	1,2,3	
		JJS, LPJ	400				
	480	100kA	LPS-RK	100	EHD	ALL	2,3
JJS, LPJ			200	EHD, FD, HFD, FDC	ALL	2,3	
KRP-C			1200	MC, HMC, NC, HNC	ALL	2,3	
200kA		KRP-C	800	MC, HMC	ALL	2,3	
				FD, HFD	ALL	2,3	
600	100kA	LPS-RK	100	FDC	ALL	2,3	
			200	JD, HJD, JDC	ALL	2,3	
			400	KD, HKD, KDC	ALL	2,3	
			600	LC	ALL	2,3	
		JJS, LPJ	200	FD, HFD	ALL	2,3	
					FDC	ALL	2,3
			400	JD, HJD, JDC	ALL	2,3	
	200kA	KRP-C	1200	LC	ALL	2,3	
		LPS-RK	400	LC	ALL	2,3	
		JJS, LPJ	600	KD, HKD, KDC, LC	ALL	2,3	

\*SCIR–Series Combination Interrupting Rating

# Cutler-Hammer Series Ratings

Panelboards: PRL 1A, PRL 2A, PRL 1A-LX, PRL 2A-LX

(See Notes Below & Page 37)

Max System Voltage	SCIR*	Line Side Fuse	Max Fuse Current Rating	Load Side		
				Circuit Breaker	Amps	Poles
120/240	100kA	LPN-RK	200	GB, GHB	ALL	1,2
		JJN, LPJ	400	BA, BAB, HQP, QBHW, QPHW	ALL	1,2
	200kA	LPN-RK	100	BA, BAB, HQP, QBHW, QPHW, GB, GHB	ALL	1,2
		JJN, LPJ	200	BA, BAB, HQP, QBHW, QPHW	ALL	1,2
		JJN, LPJ	400	GB, GHB	ALL	1,2
		JJN, LPJ	400	GHB	ALL	1,2,3
240	100kA	LPN-RK	200	GB, CA	ALL	2,3
		JJN, LPJ	400	BAB_H, QBHW_H, HQP_H, QPHW_H	ALL	2,3
		JJN	600	CA, CAH, HCA	ALL	2,3
		KRP-C	6000	EHD, FD	ALL	1,2,3
		KRP-C	6000	FDB, ED, JDB, JD, DK, KDB, KD	ALL	2,3
		JJN, LPJ	400	GHB	ALL	1,2,3
	200kA	LPN-RK	100	BAB_H, QBHW_H, HQP_H, QPHW_H, CAH, HCA, GB	ALL	2,3
		LPN-RK	200	GB, GHB	ALL	2,3
		JJN, LPJ	200	BAB_H, HQP_H, QBHW_H, QPHW_H, CA, CAH, HCA	ALL	2,3
		JJN, LPJ	400	GHB	ALL	1,2,3
		JJN, LPJ	400	GB	ALL	2,3
		JJN, LPJ	400	GB	ALL	2,3
480/277	65kA	JJS, LPJ	200	GHBS	ALL	1,2
	100kA	JJS, LPJ	100	GHBS	ALL	1,2
		LPS-RK	200	GHB	ALL	1,2,3
		LPJ	600	EHD, FD, HFD, FDC	ALL	2,3
		JJS	600	GHB, EHD, FD, HFD, FDC, JD, HJD, JDC	ALL	2,3
	200kA	LPS-RK	100	GHB	ALL	1,2,3
		JJS, LPJ	400	GHB	ALL	1,2,3

\* SCIR - Series Combination Interrupting Rating

**Notes for above Table:**

- 1) The HQP & QPHW are not listed for use in the PRL1A-LX Panel.
- 2) PRL1A & PRL1A-LX are for use at 240V maximum
- 3) Branch breakers for maximum 120/240V systems include: BAB, HQP, QBHW & QPHW.
- 4) Branch breakers for maximum 240V systems include: BAB\_H, HQP\_H, QBHW\_H & QPHW\_H.
- 5) PRL2A & PRL2A-LX, branch breakers include: GHB, GHBS & GB.
- 6) PRL1A-LX & PRL2A-LX Main & Sub-feed breakers include: ED, FD, HFD, FDC.
- 7) PRL1A & PRL2A Main & Sub-feed breakers include: CA, CAH, HCA, ED, FD, HFD, FDC, JD, HJD, JDC, KD, HKD & KDC

# Cutler-Hammer Series Ratings

Triple Series Rating - Switchboards: PRL-C & PRL-i

Panelboard Types: PRL 5P, PRL 4, PRL 3A, PRL 2A, PRL 2A-LX, PRL 1A, PRL 1A-LX

& Pow-R-Command Panels

(See Notes Below)

Max System Voltage	SCIR*	Line Side Fuse	Tenant Main Type	Branch Type		
				Circuit Breaker	Amps	Poles
120/240	100kA	KRP-C (Max Fuse Size - 6000A)	DK, KDB, KD	GB, GHB	ALL	1,2
			JD, JDB	GB, GHB	ALL	1,2
			FD	GB, GHB	ALL	1,2
			FD, FDB	HQP	15-70	1,2
			EHD	BA, BAB	ALL	1,2
240	100kA	KRP-C (Max Fuse Size - 6000A)	DK, KDB, KD	BA, BAB, HQP	ALL	1,2
				GHB	ALL	1,2,3
				GB, EHD	ALL	2,3
				CA, CAH, HCA	ALL	2,3
				FD, FDB	ALL	2,3
			JD, JDB	ALL	2,3	
			JD, JDB	GHB	ALL	1,2,3
				GB	ALL	2,3
			FD	GHB	ALL	1,2,3
				GB	ALL	2,3
			FD, FDB	BAB_H, QBHW_H, HQP_H, QPHW_H	ALL	2,3
			EHD	BAB_H, HQP_H	ALL	2,3

\* SCIR - Series Combination Interrupting Rating

NOTE (1): The data in these charts was compiled from information in Cutler-Hammer, Series Rating Information Manual, catalog reference number 1C96944H01 Rev. E, pages 18-24, and Cutler-Hammer Consulting Application Catalog 12th Edition, pages F1-11 - F1-12. Cooper Bussmann assumes no responsibility for the accuracy or reliability of the information. The information contained in the tables may change without notice due to equipment design modifications.

NOTE (2): The line-side fused switch may be in a separate enclosure or in the same enclosure as the load-side circuit breaker. A line-side fused switch may be integral or remote.

NOTE (3): Max fuse current rating denotes the largest amperage fuse that may be used for that series rated combination. A lower amperage fuse may be substituted for the listed fuse.

# GE Series Ratings

## Spectra Series

(See Notes on Page 41)

Maximum System Voltage	SCIR*	Line Side Fuse	Max Fuse Current Rating	Load Side				
				Circuit Breaker	Amps	Poles		
240Vac	42kA	JJN, LPJ	600	TJD	250-400	2, 3		
			2000	TJD	250-400	2, 3		
	100kA	KRP-C	LPJ, JJN	400	TQD	125-225	2, 3	
				600	THHQB	40-100	3	
					TQD	100-225	2	
				TQD	125-225	3		
			800	TJD	250-400	2, 3		
				SFH	70-250	2, 3		
				TJD	250-400	2, 3		
				THJK	250-600	2, 3		
	200kA	KRP-C	LPN-RK	200	TEB, TED	15-100	1, 2, 3	
					SFH, SFL	70-250	2, 3	
					SED, SEH, SEL	15-150	2, 3	
			LPJ, JJN	400	TEB	15-100	1, 2	
					TEB, TED	15-100	2, 3	
					TJD	250-400	2, 3	
					SFH, SFL	70-250	2, 3	
					600	SED, SEH, SEL	15-150	2, 3
					2000	SGD, SGH, SGL	125-600	
277Vac	100kA	LPS-RK	100	TED	15-50	1		
				THED	15-30	1		
				TEY	15-100	1		
			200	SED, SEH, SEL	15-150	2, 3		
				TEY	15-100	1		
				TED	15-50	1		
		LPJ, JJS	400	TED	15-50	1		
				THED	15-30	1		
				SED, SEH, SEL	15-150	2, 3		
			600	TEY	15-100	1		
				SED, SEH, SEL	15-150			
480Vac	65kA	LPJ	600	TED, THED	15-150	2, 3		
			100	TED, THED6	15-100	2, 3		
	100kA	LPS-RK	200	TEY	15-100	2, 3		
				SED, SEH, SEL	15-150	2, 3		
				TED	15-50	1		
			400	TED, THED6	15-100	2, 3		
				SFH, SFL	70-250	2, 3		
		600	SGH, SGL	125-600	2, 3			
			TEY	15-100	2, 3			
			SED, SEH, SEL	15-150	2, 3			
		JJS	800	SKH, SKL	300-1200	2, 3		
				THJK	125-600	2, 3		
	2000			SKH, SKL	300-1200	2, 3		
	KRP-C		2000	SGH, SGL	125-600	2, 3		
				2000	TPV, THPV	800A FRAME (1)	3	
				2500	TPV, THPV	2500A FRAME (1)	3	
	200kA	KRP-C	2000	TPV, THPV	800A FRAME (1)	3		
			2500	TPV, THPV	2500A FRAME (1)	3		
600Vac	200kA	KRP-C	2000	TPV, THPV	800A FRAME (1)	3		
			2500	TPV, THPV	2500A FRAME (1)	3		

\*SCIR–Series Combination Interrupting Rating

(1) Includes all sensor/rating plug or setting values within stated frame size.

# GE Series Ratings

## AL / AQ PANELBOARD

(See Notes on Page 41)

Maximum System Voltage	SCIR*	Line Side Fuse	Max Fuse Current Rating	Load Side				
				Circuit Breaker	Amps	Poles		
240Vac	42kA	JJN	600	THQL-GF	15-30	1		
				THQL	15-100 (2)	1, 2, 3		
		JJN, LPJ	600	TJD	250-400	2, 3		
	KRP-C	2000	TJD	250-400	2, 3			
	65kA	JJN	600	THHQL	15-70	1		
				THHQL	15-125	2		
		JJN, LPJ, LPN-RK	600	TFJ	70-225	2, 3		
	KRP-C	3000	TFJ	70-225	2, 3			
	100kA	LPN-RK	200	THQL	15-100 (2)	1, 2, 3		
				JJN	200	THQP	15-50	1, 2
				LPJ, JJN	400	THQL	15-100 (2)	1, 2, 3
		TQD	125-225			2, 3		
		THHQL, THHQB	40-100			3		
		600	TFJ		70-225	2, 3		
			TQD		100-225	2		
			TQD		125-225	3		
		KRP-C	1200	TJD	250-400	2, 3		
				TFJ	70-225	2, 3		
				SFH	70-250	2, 3		
		200kA	LPN-RK	200	TJD	250-400	2, 3	
	THQL				15-100 (2)	1, 2		
	TFJ				70-200	2, 3		
	LPJ, JJN		400	SFH, SFL	70-250	2, 3		
				SED, SEH, SEL	15-150	2, 3		
THQL				15-100 (2)	1, 2			
600			TFJ	70-225	2, 3			
			TJD	250-400	2, 3			
			SFH, SFL	70-250	2, 3			
KRP-C	2000	SED, SEH, SEL	15-150	2, 3				
SGD, SGH, SGL	125-600							

(2) THQL 1 pole rating is 70 amperes maximum. Maximum system voltage is 120/240Vac.  
THQL 2 pole 110-125A ratings are also series rated on 120/240Vac maximum services.

## ALC / AQC Panelboard

(See Notes on Page 41)

Maximum System Voltage	SCIR*	Line Side Fuse	Max Fuse Current Rating	Load Side				
				Circuit Breaker	Amps	Poles		
240Vac	42kA	JJN	600	THQL-GF	15-30	1		
				THQL	15-100 (2)	1, 2, 3		
	65kA	JJN	600	THHQL	15-70	1		
				THHQL	15-125	2		
		JJN, LPJ, LPN-RK	600	TFJ	70-225	2, 3		
	KRP-C	3000	TFJ	70-225	2, 3			
	100kA	LPN-RK	200	THQL	15-100 (2)	1, 2, 3		
				JJN	200	THQP	15-50	1, 2
				LPJ, JJN	400	THQL	15-100 (2)	1, 2, 3
		TQD	125-225			2, 3		
		THHQL, THHQB	40-100			3		
		600	TFJ		70-225	2, 3		
			TQD		100-225	2		
			TQD		125-225	3		
		KRP-C	1200	TFJ	70-225	2, 3		
				SFH	70-250	2, 3		
				200kA	LPN-RK	200	THQL	15-100 (2)
		TFJ	70-200				2, 3	
	SFH, SFL	70-250	2, 3					
	LPJ, JJN	400	SED, SEH, SEL		15-150	2, 3		
			THQL		15-100 (2)	1, 2		
			TFJ		70-225	2, 3		
		600	SFH, SFL		70-250	2, 3		
			SED, SEH, SEL		15-150			

\*SCIR—Series Combination Interrupting Rating

(2) THQL 1 pole rating is 70 amperes maximum. Maximum system voltage is 120/240Vac.  
THQL 2 pole 110-125A ratings are also series rated on 120/240Vac maximum services.



# GE Series Ratings

## AE / AD PANELBOARD

(See Notes on Page 41)

Maximum System Voltage	SCIR*	Line Side Fuse	Max Fuse Current Rating	Load Side			
				Circuit Breaker	Amps	Poles	
277Vac	100kA	LPS-RK	100	TED	15-50	1	
				THED	15-30	1	
				TEY	15-100	1	
			200	SED, SEH, SEL	15-150	2, 3	
				TEY	15-100	1	
				TED	15-50	1	
		LPJ, JJS	400	TED	15-50	1	
				THED	15-30	1	
				SED, SEH, SEL	15-150	2, 3	
			600	TEY	15-100	1	
				SED, SEH, SEL	15-150		
480Vac	65kA	LPJ	600	TED, THED	15-150	2, 3	
			100	TED, THED6	15-100	2, 3	
	100kA	LPS-RK	200	TEY	15-100	2, 3	
				SED, SEH, SEL	15-150	2, 3	
				TED	15-50	1	
			LPJ, JJS	400	TED, THED6	15-100	2, 3
					TFJ	70-225	2, 3
					TJJ	125-400	2, 3
	SFH, SFL	70-250			2, 3		
	SGH, SGL	125-600			2, 3		
	TEY	15-100			2, 3		
	JJS	800	SED, SEH, SEL	15-150	2, 3		
			SKH, SKL	300-1200	2, 3		
		1200	TJJ	125-400	2, 3		
			KRP-C	2000	SKH, SKL	300-1200	2, 3
	SGH, SGL	1					

## AEC PANELBOARD

(See Notes on Page 41)

Maximum System Voltage	SCIR*	Line Side Fuse	Max Fuse Current Rating	Load Side			
				Circuit Breaker	Amps	Poles	
277Vac	100kA	LPS-RK	100	TED	15-50	1	
				TEY	15-100	1	
				SED, SEH, SEL	15-150	2, 3	
			200	TEY	15-100	1	
				TED	15-50	1	
				TED	15-50	1	
		LPJ, JJS	400	SED, SEH, SEL	15-150	2, 3	
				TEY	15-100	1	
				SED, SEH, SEL	15-150		
			600	TEY	15-100	1	
				SED, SEH, SEL	15-150		
480Vac	65kA	LPJ	600	TED	15-150	2, 3	
			100	TED	15-100	2, 3	
	100kA	LPS-RK	200	TEY	15-100	2, 3	
				SED, SEH, SEL	15-150	2, 3	
				TED	15-50	1	
			LPJ, JJS	400	TED	15-100	2, 3
					TFJ	70-225	2, 3
					SFH, SFL	70-250	2, 3
	SGH, SGL	125-600			2, 3		
	TEY	15-100			2, 3		
	SED, SEH, SEL	15-150					

\*SCIR–Series Combination Interrupting Rating

# GE Series Ratings

Note: The following circuit breakers may be substituted for the circuit breakers shown in the series rating tabulations. Devices with MicroVersaTrip Plus and PM trip units may also be substituted, provided the short circuit rating is equal to or greater than series connected rating. Ref. GE publication DET-008A.

Breaker	Substitute Breaker(s)
THQL	THQB, THQC, THQE, THHQL, THHQB, THHQC
THHQL	THHQB, THHQC
THQL-GF	THQB-GF, THQC-GF
TED	THED
SED	SEH, SEL, SEP
SEH	SEL, SEP
SEL	SEP
TQD	THQD
TFJ	TFK, THFK
SFH	SFL, SFP
SFL	SFP
TJJ	TJK, THJK, TJ4V, THJ4V, THJ9V, TJH
THJK	THJ4V, THJ9V, TJH, TJL
SGD	SGH, SGL, SGP
SGH	SGL, SGP
SGL	SGP
SKH	SKL, SKP
SKL	SKP
TPV	SS, SH, TP, TC, TCV, THP, THC, THCV
THPV	SH, THP, THC, THCV

NOTE 1: The data in these charts was compiled from information in GE Electrical Distribution & Control publication, catalog reference number GEP-1100P and GE Electrical Distribution & Control publication - UL Component Recognized Series Ratings, publication reference number DET-008A. Cooper Bussmann assumes no responsibility for the accuracy or reliability of the information. The information contained in the tables may change without notice due to equipment design modifications.

NOTE 2: The line-side fused switch may be in a separate enclosure or in the same enclosure as the load-side circuit breaker. A line-side fused switch may be integral or remote.

NOTE 3: Max fuse current rating denotes the largest amperage fuse that may be used for that series rated combination. A lower amperage fuse may be substituted for the listed fuse.

# Siemens Series Ratings

Switchboards SB1, SB2, SB3  
Panelboard S1

(See Notes on Page 43)

Max System Voltage	SCIR*	Line Side Fuse	Max Fuse Current Rating	Load side					
				Circuit Breaker	Amps	Poles			
120/240Vac	65kA	LPJ, LPN-RK	600	QPH, BQH, BLH	15-70	1 (120V)			
		JJN (300V)	1200		15-125	2			
		KRP-C	6000		15-100	3			
	100kA	JJN (300V)	200	200	QP, BQ, BL	15-70	1 (120V)		
					15-125	2			
					15-100	3			
					HQP, HBQ, HBL, QPH, BQH, BLH	15-100	3		
					QPF, BQF, BLF, QE, BE, BLE, QEH, BLEH, BLHF, QPHF, BQHF	15-30	1 (120V)		
					QE, BLEH, QE, QPHF, BLHF, BLE, QPF, BLF	15-60	2		
		QT	15-50	1 (120V),2					
		600	600	600	600	QPH, BQH, BLH, HQP, HBQ, HBL	15-70	1 (120V)	
						15-125	2		
15-100	3								
240Vac	100kA	LPJ, LPN-RK	600	ED4, HED4	15-100	1 (120V)			
				ED4, ED6, HED4, HED6	15-125	2,3			
				FD6-A, FXD6-A	70-250	2,3			
				JD6-A, JXD6-A, JXD2-A, SJD6-A	200-400	2,3			
				LD6-A	200-600	2,3			
				SLD6-A	300-600	3			
		LXD6-A	450-600	2,3					
		JJN (300V)	1200	1200	1200	ED4, HED4	15-100	1 (120V)	
						ED4, ED6, HED4, HED6	15-125	2,3	
						FD6-A, FXD6-A	70-250	2,3	
						JD6-A, JXD6-A, JXD2-A, SJD6-A	200-400	2,3	
						LD6-A	200-600	2,3	
	SLD6-A					300-600	3		
	LXD6-A	450-600	2,3						
	KRP-C	6000	6000	6000	ED4, HED4	15-100	1 (120V)		
					ED4, ED6, HED4, HED6	15-125	2,3		
					FD6-A, FXD6-A	70-250	2,3		
					JD6-A, JXD6-A, JXD2-A, SJD6-A	200-400	2,3		
					LD6-A	200-600	2,3		
					SLD6-A	300-600	3		
		LXD6-A	450-600	2,3					
		SMD6	500-800	3					
		SND6	500-1200	3					
		PD6, PXD6, SPD6	1200-1600	3					
		RD6, RXD6	1600-2000	3					
		200kA	LPN-RK	200	200	QJH2, QJ2H, QJ2	125-200	2,3	
	JJN (300V)					400	QJ2	125-225	2,3
	LPJ					600	QJH2, QJ2H	125-225	2,3
	LPJ, LPN-RK					600	HFD6, HFXD6	70-250	2,3
	JJN (300V)					1200	HFD6, HFXD6	70-250	2,3
JJN (300V)	1200					HFD6, HFXD6	70-250	2,3	
KRP-C	6000		6000	6000	HFD6, HFXD6	70-250	2,3		
					MD6, MXD6, HMD6, HMXD6	500-800	2,3		
					ND6, NXD6, HND6, HNXD6	500-1200	2,3		

\*SCIR-Series Combination Interrupting Rating

# Siemens Series Ratings

**Switchboards SB1, SB2, SB3**  
**Panelboards S2, SE, S3, S4, S5**

(See Notes Below)

Max System Voltage	SCIR*	Line Side Fuse	Max Fuse Current Rating	Load side		
				Circuit Breaker	Amps	Poles
480Vac	50kA	LPJ	400	ED4	60-100	1 (277V)
					15-100	2,3
	100kA	LPJ	400	ED4	15-50	1 (277V)
					JJS, LPJ	600
		LPJ, LPS-RK	600	HFD6, HFXD6	70-250	2,3
		JJS, LPJ, LPS-RK	600	JD6-A, JXD6-A, HJD6-A, HJXD6-A	200-400	2,3
				LD6-A, HLD6-A	200-600	2,3
				LXD6-A, HLXD6-A	450-600	2,3
		JJS	800	HFD6, HFXD6	70-250	2,3
		JJS, KRP-C	1200	JD6-A, JXD6-A, HJD6-A, HJXD6-A	200-400	2,3
				LD6-A, HLD6-A	200-600	2,3
				LXD6-A, HLXD6-A	450-600	2,3
	HFD6, HFXD6			70-250	2,3	
	KRP-C	6000	MD6, MXD6, HMD6, HMXD6	500-800	2,3	
ND6, NXD6, HND6, HNXD6			500-1200	2,3		
480/277V	200kA	LPS-RK	100	BQD, CQD	15-100	1 (277V)
				BQD**, CQD **	20-30	2,3
		JJS, LPJ	200	BQD, CQD	15-100	1 (277V)
				BQD**, CQD **	20-30	2,3

\*SCIR–Series Combination Interrupting Rating

\*\*BQD and CQD breakers are series rated from 15-100A for Series 7A, S2 and S3 panelboard applications only.

NOTE (1): The data in these charts was compiled from information in Siemens SpeedFax 2000 Electrical Products publication, catalog reference number GNPC-01000. Cooper Bussmann assumes no responsibility for the accuracy or reliability of the information. The information contained in the tables may change without notice due to equipment design modifications.

NOTE (2): The line-side fused switch may be in a separate enclosure or in the same enclosure as the load-side circuit breaker. A line-side fused switch may be integral or remote.

NOTE (3): Max fuse current rating denotes the largest amperage fuse that may be used for that series rated combination. A lower amperage fuse may be substituted for the listed fuse.

# Square D Series Ratings

## I-Line Switchboard/Panelboard

(See Notes on Page 45)

Maximum System Voltage	SCIR*	Line Side Fuse	Max Fuse Current Rating	Load Side		
				Circuit Breaker	Amps	Poles
240Vac	100kA	LPN-RK	600	FH, KA, KH, LA, LH, MA, MH, MX	ALL	2, 3
		JJS	600	FA	ALL	2, 3
		JJS	800	FH, KA, KH, LA, LH, MA, MH, MX	ALL	2, 3
		LPJ	600	FA, FH, KA, KH, LA, LH, MA, MH, MX	ALL	2, 3
		KRP-C	800	KA	ALL	2, 3
		KRP-C	1200	FH, LA, LH	ALL	2, 3
		KRP-C	2000	KH, MA, MH, MX	ALL	2, 3
	200kA	LPN-RK	600	FH, FC, KH, KC, LA, LH, LC, LX, MA, MH, MX, NA, NC, NX	ALL	2, 3
		JJS	600	FA	ALL	2, 3
		JJS	800	FH, FC, KA, KH, KC, LA, LH, LC, LX, MA, MH, MX, NA, NC, NX	ALL	2, 3
		LPJ	600	FA, FH, FC, KA, KH, KC, LA, LH, LC, LX, MA, MH, MX, NA, NC, NX	ALL	2, 3
		KRP-C	800	FH, LA, LH	ALL	2, 3
		KRP-C	1200	FC, KH, KC, LC, LX, MA, MH, MX	ALL	2, 3
		KRP-C	2000	NA, NC, NX	ALL	2, 3
480Vac	100kA	LPS-RK	600	FC, KA, KH, KC, LA, LH, LC, LX, MA, MH, MX, NA	ALL	2, 3
		JJS	600	FA, FH	ALL	2, 3
		JJS	800	FC, KA, KH, KC, LA, LH, LC, LX, MA, MH, MX, NA	ALL	2, 3
		LPJ	600	FA, FH, FC, KA, KH, KC, LA, LH, LC, LX, MA, MH, MX, NA	ALL	2, 3
		KRP-C	800	KA	ALL	2, 3
		KRP-C	1200	KH, LA, LH		
		KRP-C	1600	MA		
	KRP-C	2000	FC, KC, LC, LX, MH, MX, NA			
	200kA	LPS-RK	600	FC, KC, LA, LH, LC, LX, MA, MH, MX, NA, NC, NX	ALL	2, 3
		JJS	400	FA, FH	ALL	2, 3
		JJS	800	FC, KA, KH, KC, LA, LH, LC, LX, MA, MH, MX, NA, NC, NX	ALL	2, 3
		LPJ	400	FA, FH	ALL	2, 3
		LPJ	600	FC, KA, KH, KC, LA, LH, LC, LX, MA, MH, MX, NA, NC, NX	ALL	2, 3
		KRP-C	800	LA, LH	ALL	2, 3
KRP-C		1200	FC, KC, LC, LX, MA, MH, MX	ALL	2, 3	
KRP-C	2000	NA, NC, NX	ALL	2, 3		

\*SCIR–Series Combination Interrupting Rating

# Square D Series Ratings Chart

## NQOD Panelboards

(See Notes below)

Maximum System Voltage	SCIR*	Line Side Fuse	Max Fuse Current Rating	Load Side		
				Circuit Breaker	Amps	Poles
240Vac	200kA	JJS, LPJ	200	QO, QOB	ALL	1, 2, 3
				QO, QOB (AS)	ALL	1, 2, 3
				QO, QOB (GF I)	ALL	1, 2, 3
		JJN	400	QO, QOB	ALL	1, 2, 3
				QO, QOB (AS)	ALL	1, 2, 3
				QO, QOB (GF I)	ALL	1, 2, 3

Note for NQOD Panelboards: 1P for use at 120V Only

## NEHB Panelboards

(See Notes Below)

Maximum System Voltage	SCIR*	Line Side Fuse	Max Fuse Current Rating	Load Side		
				Circuit Breaker	Amps	Poles
480Y/277Vac	100kA	JJS, LPJ	200	EH, EHB	ALL	1, 2, 3

Note for NEHB Panelboards: 1P for use at 277V Only

## NF Panelboard

(See Notes Below)

Maximum System Voltage	SCIR*	Line Side Fuse	Max Fuse Current Rating	Load Side		
				Circuit Breaker	Amps	Poles
480Y/277Vac	100kA	JJS, LPJ	400	EDB, EGB, EJB	ALL	1, 2, 3
	200kA	JJS, LPJ	200			

Note for NF Panelboards: 1P for use at 277V Only

## SF Switchboards with I-Line or NQOD Distribution

(See Notes Below)

Maximum System Voltage	SCIR*	Line Side Fuse	Max Fuse Current Rating	Load Side		
				Circuit Breaker	Amps	Poles
120/240Vac	42kA	JJS	400	QO-VH, QOB-VH	ALL	1 (120V)
240Vac	42kA	JJS	800	QO-VH, QOB-VH, FA, Q4	ALL	2, 3
				Q2-H	ALL	2
480Vac	50kA	JJS	800	FA, FH	ALL	2, 3
	65kA	JJS	800	KA, KH, LA, LH	ALL	

\*SCIR–Series Combination Interrupting Rating

NOTE (1): The data in these charts was compiled from information in Square D, Series Rating Data Bulletin No. 2700DB9901 and Square D Digest 171. Cooper Bussmann assumes no responsibility for the accuracy or reliability of the information. The information contained in the tables may change without notice due to equipment design modifications

NOTE (2): The line-side fused switch may be in a separate enclosure or in the same enclosure as the load-side circuit breaker. A line-side fused switch may be integral or remote.

NOTE (3): Max fuse current rating denotes the largest amperage fuse that may be used for that series rated combination. A lower amperage fuse may be substituted for the listed fuse.